



Report for the ACCC

Bottom-up cost model for voice interconnection services

James Allen, Matthew Starling, Juliette Welham

August 2025

Ref: 656748795-300R

Contents

1	Introduction	1
1.1	Background	1
1.2	Previous work	2
1.3	Overview of modelling approach	2
1.4	Conceptual approach	3
1.5	Structure of this document	4
2	Overview of the model	5
2.1	Long-run incremental costing (LRIC)	5
2.2	Calculation stages	5
2.3	Worksheets	6
2.4	Key dimensions	7
3	Model implementation	12
3.1	Market calculations	12
3.2	Radio layer	24
3.3	Core layer	27
3.4	Network expenditure	30
3.5	Service costing	36
4	Finding and recommendations	40
4.1	Description of base case	40
4.2	Cost results	41
4.3	Sensitivity tests	42
Annex A	Expansion of acronyms	
Annex B	Coverage calculations	
Annex C	Derivation of inputs for the model	
Annex D	Overview of the network design calculation flows	
Annex E	Overview of the costing calculation flows	

Copyright © 2025. Analysys Mason has produced the information contained herein for the Australian Competition and Consumer Commission (ACCC). The ownership, use and disclosure of this information are subject to the Commercial Terms contained in the contract between Analysys Mason and the ACCC.

Analysys Mason Limited
North West Wing, Bush House
Aldwych
London WC2B 4PJ
UK
Tel: +44 (0)20 7395 9000
enquiries@analysismason.com
www.analysismason.com
Registered in England and Wales No. 5177472

1 Introduction

1.1 Background

In June 2024, the Australian Competition and Consumer Commission (ACCC) commenced a public inquiry into access determinations for voice interconnection services.¹ These are wholesale services provided by mobile network operators (MNOs) or fixed network operators (FNOs) to enable subscribers from different networks to originate and terminate voice calls to each other. The three voice interconnection services of interest are:

- mobile terminating access service (MTAS)
- fixed terminating access service (FTAS)
- fixed originating access service (FOAS).

All three services are declared services under section 152AL of the Competition and Consumer Act 2010.² The current declarations of the voice interconnection services are in force until 30 June 2029. The ACCC may set price-related and non-price-related terms and conditions of access to a declared service by making an access determination relating to that service, which is a key objective for the public inquiry.

The ACCC has commissioned Analysys Mason Limited (Analysys Mason) to construct a cost model to derive network costs for these voice interconnection services. Analysys Mason has planned a three-phase approach to achieve the project objectives:

- **Phase 1 – Model specification:** collecting data and developing a model specification to set out the approach, in co-operation with industry parties through a public consultation.
- **Phase 2 – Model development:** building and populating a draft cost model, with a supporting draft report and operating manual, undertaking top-down validation and preparing the draft cost model for consultation with industry parties.
- **Phase 3 – Model consultation:** reviewing stakeholder responses to the public consultation on the draft model and updating both the cost model and accompanying documentation accordingly.

As one output for Phase 2, Analysys Mason has drafted this report to outline the structure, inputs and outputs of the cost model that has been developed according to the model specification finalised in Phase 1. Separately, data has been collected from stakeholders in Australia (national MNOs and FNOs) to collate relevant data to inform the inputs of the modelling and improve its accuracy.

¹ See the ACCC's website [here](#).

² Available at <https://www.legislation.gov.au/C2004A00109/latest/versions>

1.2 Previous work

The previous public inquiry for the MTAS concluded on 2 October 2020.³ In order to determine regulated prices for the MTAS within that inquiry, Analysys Mason developed a bespoke benchmark, adapting nine existing cost models published by other telecoms regulators to reflect the specificities of deploying national mobile networks in Australia. In this document, we refer to this past modelling exercise as the ‘2020 MTAS cost modelling’.

The approaches taken to reflect Australian specificities in the 2020 MTAS cost modelling have been retained, reused or adapted at multiple points where appropriate in the model development.

1.3 Overview of modelling approach

The objective is to construct a cost model for voice interconnection services for the ACCC, to provide cost-based information for price regulation of the MTAS, the FTAS and the FOAS. This model has been developed using demand and network parameter information submitted by stakeholders in Australia, combined with estimates and calculations performed by Analysys Mason.

The three broad types of input that will feed into the model relate to demand volumes, network design parameters and cost assumptions, as shown in Figure 1.1 below.

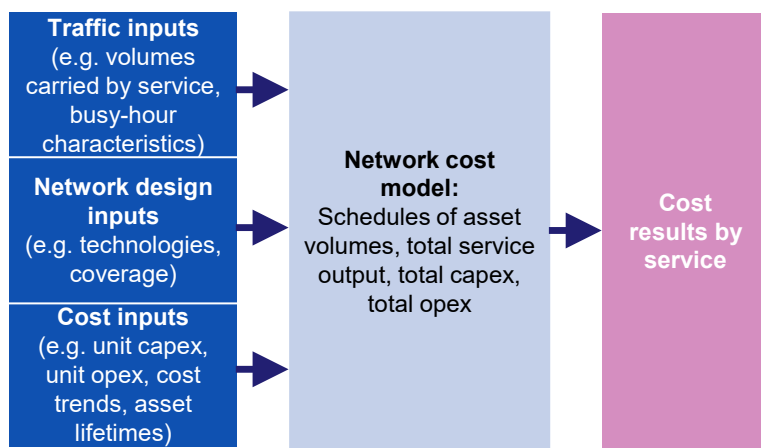

Figure 1.1: Roadmap of the cost model
[Source: Analysys Mason, 2025]

A national MNO has been modelled to calculate the relevant costs of MTAS.

FTAS and FOAS are provided over fixed networks. However, the convention in cost recovery of fixed networks is that the costs of the access network infrastructure are recoverable from access line charges and the costs of core network infrastructure are recoverable from traffic-related charges (such as the FTAS and the FOAS). Therefore, only a fixed core network is considered in our model.

It is anticipated that a variety of network configurations can be considered by choosing appropriate input parameters in the model, including (but not limited to) market share, spectrum and coverage. For a configuration defined by a given set of inputs, the model derives the assets in a forward-

³ See the ACCC’s website [here](#).

looking manner and then determines the costs of these assets over a specified timeframe. These costs are then recovered by the services assumed to be conveyed over this network during its lifetime. Capital costs are calculated using a weighted average cost of capital (WACC), which is determined separately by the ACCC. No remaining terminal value is applied within the model at the end of the cost recovery period.

1.4 Conceptual approach

Analysys Mason has developed a conceptual framework that it has applied in dozens of network costing projects over the last 25 years. This framework covers four dimensions, as shown in Figure 1.2 below.

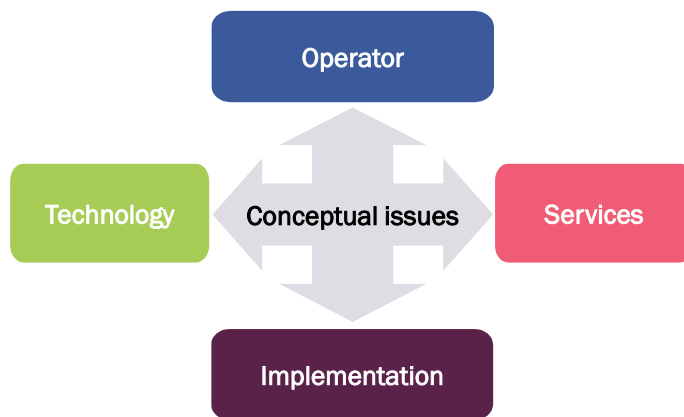

Figure 1.2: Conceptual framework [Source: Analysys Mason, 2025]

The four dimensions are outlined below:

- **Operator dimension:** defines the scale/scope of the modelled operator (e.g. should any aspect of the modelled scale and scope be hypothetical, or should actual operations be entirely reflected in the model?).
- **Technology dimension:** sets out the choice of network technologies to be assumed for the modelled operator.
- **Service dimension:** considers the relevant services to be provided by the modelled operator.
- **Implementation dimension:** defines associated computational aspects (e.g. modelling period, depreciation method, use of mark-ups, approaches to modelling specific costs).

Our proposed framework is described in the final model specification produced for the ACCC.

1.5 Structure of this document

The remainder of this document is laid out as follows:

- Section 2 provides an overview of the model
- Section 3 describes the model implementation
- Section 4 provides the outputs and our recommendations of the draft model.

The report also includes five supplementary annexes:

- Annex A provides a list of the acronyms used and what each stands for
- Annex B describes how coverage inputs are derived in the model
- Annex C describe how we have used data from operators to derive key inputs in the model
- Annex D provides an overview of the network design calculation flows
- Annex E provides an overview of the costing calculation flows.

2 Overview of the model

This section provides an overview of the model, including

- long-run incremental costing in Section 2.1
- calculation stages in Section 2.2
- model structure in Section 2.3
- key dimensions in Section 2.4.

2.1 Long-run incremental costing (LRIC)

The ACCC has already taken a pricing position where it considers the appropriate approach to voice interconnection costing to be a total service long-run incremental cost approach plus an allowance for common costs (TSLRIC+). This is equivalent to a long-run average incremental costing (LRAIC+) methodology in our model. This considers a large increment (e.g. all traffic services provided by the network) and allocates the incremental cost of traffic between the volumes of these services, using ‘average traffic routing factors.’ Each service, including voice interconnection services, therefore receives a share of intra-traffic network common costs. One or more mark-ups are applied to the network costs to capture other common costs (e.g. business overheads).

2.2 Calculation stages

Figure 2.1 below provides an overview of the calculation stages in the model and the worksheets on which they are carried out.

Figure 2.1: Overview of calculation stages in the model [Source: Analysys Mason, 2025]

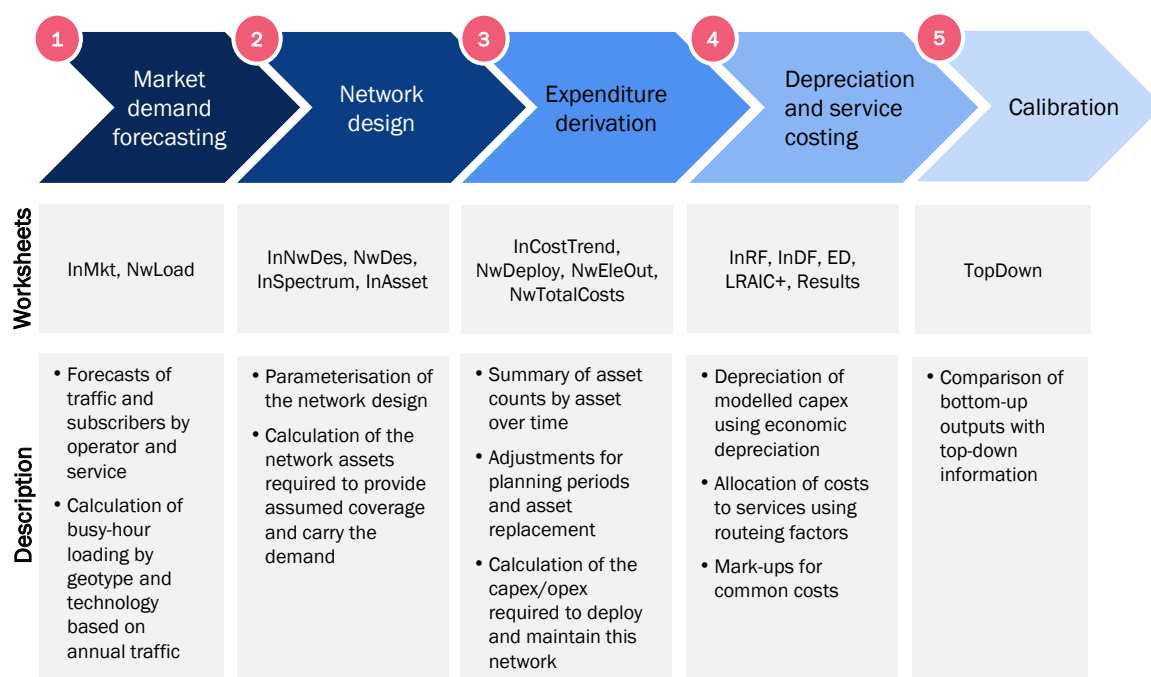

2.3 Worksheets

The model consists of the following worksheets that undertake the described functions.

Figure 2.2: Worksheets in the bottom-up cost model for the ACCC [Source: Analysys Mason, 2025]

Sheet name	Description
C	The contents worksheet: lists the worksheets in the workbook
V	A history of the versions of this workbook
S	A guide to the styles used in this workbook
Ctrl	Dashboard for the model
InLists	Stores key lists for the model
InMkt	Parameterises market-level demand forecasts and calculates market volumes
InSpectrum	Specifies the spectrum-related inputs for the model (allocations and payments)
InNwDes	Specifies a wide range of inputs used in the design of the network
InRF	Specifies the routeing factors
InCostTrend	Specifies the capex and opex cost trends for the model
InDF	Specifies the assumed inflation rate
NwLoad	Calculates the total and peak traffic load of the modelled operator's network
NwDes	Calculates asset requirements over time for the modelled operator's network
NwDeploy	Calculates the number of assets, reflecting retirement, activation and purchase
NwEleOut	Calculates the routeing factor-weighted output of each asset
NwTotalCost	Calculates the total annual investment and total annual operating costs
ED	Calculates annualised cost according to economic depreciation

Sheet name	Description
<i>LRAIC+</i>	Calculates average incremental costs for all services
<i>Results</i>	Output worksheet of key results
<i>TopDown</i>	Compares key outputs with top-down data

2.4 Key dimensions

In this section, we describe three of the key dimensions captured in the modelling:

- geotypes (which capture network variations by geography), described in Section 2.4.1
- modelling years (which determine the years in which costs are incurred and recovered), described in Section 2.4.2
- service list (which set out the services that use the network and are allocated costs to ensure cost recovery), described in Section 2.4.3.

2.4.1 Geotypes

We have used statistical local areas level 2 ('SA2') areas as the starting point for the geotypes in the cost model, of which there are approximately 2500 in Australia.⁴ We have further split these areas based on the Australian Bureau of Statistics (ABS) definition of remoteness areas.⁵ Remoteness areas are scored using an index called the Accessibility/Remoteness Index of Australia Plus (ARIA+). The five remoteness area types are:

- Major cities
- Inner Regional
- Outer Regional
- Remote
- Very Remote.

The splitting of SA2 areas by remoteness leads to 9434 separate pieces of land, of which 6624 are islands. For each piece of land, we have calculated the population using the SA1 areas.⁶

Other than mainland Australia and Tasmania, all islands are allocated their own geotype (geotype 15).

We have then assigned a geotype to the remaining 2810 areas based on their population density. The definition and information for the resulting geotypes are shown below in Figure 2.3.

⁴ The population and area for each SA2 area is available [here](#).

⁵ See the ABS website [here](#).

⁶ We use the file "2021Census_G01_AUST_SA1.csv", downloaded from <https://www.abs.gov.au/census/find-census-data/datapacks?release=2021&product=GCP&geography=SA1&header=S>

Figure 2.3: Summary of geotypes [Source: Analysys Mason, 2025]

No.	Remoteness category	Population density definition	Population (2021)	Area (km ²)	Number of areas
1	Major Cities: Very High Density	>2500	6 142 440	1665	439
2	Major Cities: High Density	1000–2500	7 871 865	4715	634
3	Major Cities: Medium Density	100–1000	4 158 635	10 412	367
4	Major Cities - Low Density	<100	138 112	3615	117
5	Inner Regional: Medium/high density	>100	2 281 781	8376	226
6	Inner Regional: Low density	<100	2 212 830	247 196	412
7	Outer Regional: Medium/high density	>100	868 705	2800	120
8	Outer Regional: Low density	<100	1 169 603	784 461	330
9	Remote: Medium/High density	>100	101 370	506	11
10	Remote: Low density	<100	172 500	908 388	85
11	Very Remote: Medium/high density	>100	11 599	41	3
12	Very Remote: Lower density	<100	146 294	5 698 701	66
13	Unused spare	n/a	–	–	–
14	Major transport routes in remote areas	n/a	–	23 071 ⁷	–
15	Islands	n/a	93 902	31 945	6 624
TOTAL			25 369 636	7 702 821	9 434

The radio and aggregation network is dimensioned by geotype, and the totals for each remoteness area type are passed through the model.

Discussion of geotype 14

Geotype 14 has been defined using the national highway routes available from the Digital Atlas of Australia.⁸ The length of these routes in remote and very remote areas have been calculated.

The routes captured in this way are illustrated below in Figure 2.4.

⁷ Of this area, 15 192km² is located in very remote areas and 7879km² in remote areas.

⁸ <https://digital.atlas.gov.au/pages/transport>

Figure 2.4: Overview of national highway routes (remote and very remote highways that are included are shown in red, remaining highways are shown in grey) [Source: Analysys Mason, 2025]

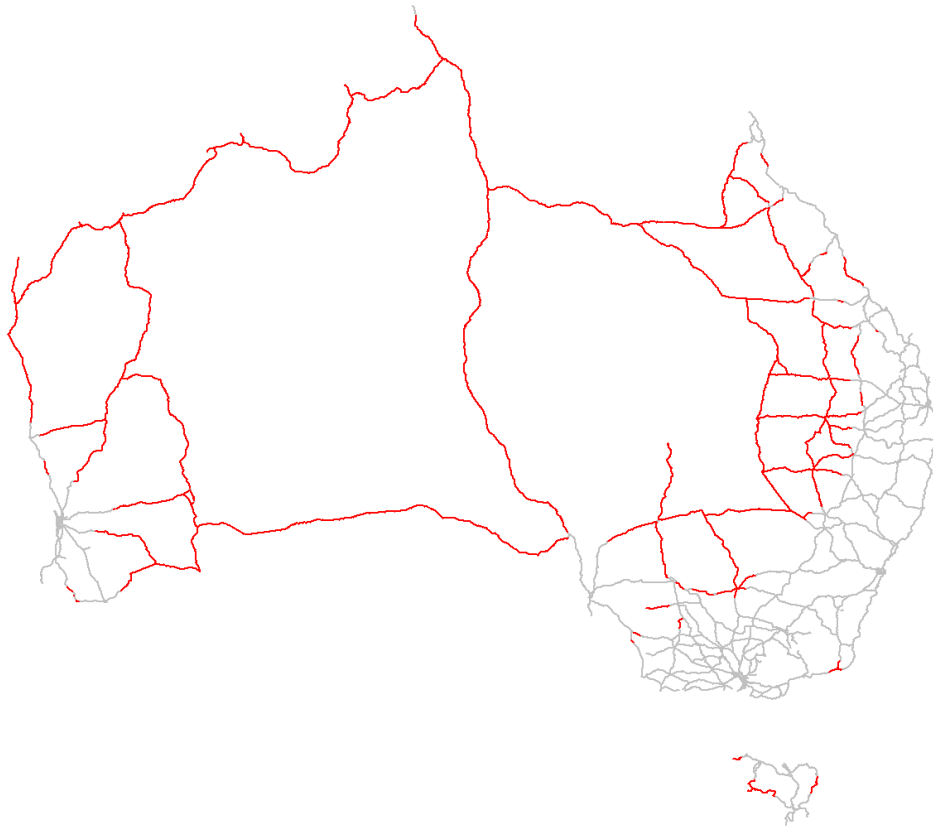

The model assumes by default that routes in both remote and very remote areas are included, but this geotype can be restricted to very remote routes only (on the basis that the remote routes could be already covered by other population-based coverage). This approach (not including “remote” in Geotype 14) is intended to avoid double counting road coverage that is achieved through coverage from sites in other geotypes.

A proportion of the included route distance in Geotype 14 is then assumed to be covered: separate proportions are specified for the 4G and 5G networks. Coverage sites in this geotype are calculated assuming 2-sectored sites and an assumed cell diameter (rather than cell area).

2.4.2 Modelling years

The model uses a calculation timeframe from 2020 to 2070, with the network assumed to be activated in 2025. The years prior to 2025 allow for the capture of planning periods, during which some assets are purchased ahead of their installation or activation. A last year of investment can also be specified on the Ctrl worksheet.

2.4.3 Services

We outline below the service set for the modelled mobile networks and fixed core networks. These reflect the definitions of the MTAS, FTAS and FOAS services.

Mobile networks

The services that we consider for the mobile networks are listed in Figure 2.5. Where we state that a subscriber is hosted by the modelled operator, we mean the subscriber is part of either the retail or wholesale (MVNO/SP) subscriber bases of the operator, or is an inbound roamer on the network.

Figure 2.5: Mobile network traffic services [Source: Analysys Mason, 2025]

Service	Explanation
On-net mobile calls	Voice calls between two subscribers hosted by the modelled operator
Outgoing mobile calls to other destinations	Voice calls from a subscriber hosted by the modelled operator to either: <ul style="list-style-type: none"> • a mobile subscriber of another domestic mobile operator • a fixed-line subscriber (including non-geographic numbers, etc.) • an international destination
Domestic incoming mobile voice (part of MTAS)	Voice calls terminated to a subscriber hosted by the modelled operator from: <ul style="list-style-type: none"> • a mobile subscriber of another domestic mobile operator • a fixed destination • an international destination
Outgoing VoWiFi	Voice calls originated from subscribers hosted by the modelled operator using either a Wi-Fi network
Incoming VoWiFi (part of MTAS)	Voice calls terminated to subscribers hosted by the modelled operator using either a Wi-Fi network
On-net SMS/MMS	SMS/MMS between two subscribers hosted by the modelled operator
Outgoing SMS/MMS	SMS/MMS from a subscriber hosted by the modelled operator to another mobile operator
Incoming SMS/MMS	SMS/MMS received from another mobile operator and terminated to a mobile subscriber hosted by the modelled operator
Packet data	Megabytes of data (excluding IP overheads) transferred to/from a mobile subscriber hosted by the modelled operator

The services set out above are also modelled separately for each radio technology (i.e. 4G and 5G), in order to capture the different levels of resources consumed per unit of traffic on each technology.

Fixed core networks

The voice services that we consider for the modelled IMS core for fixed network services are listed in Figure 2.6 below. We assume that the fixed-line subscribers in question each have a geographic number assigned to them.

Figure 2.6: Fixed core network traffic services [Source: Analysys Mason, 2025]

Service	Explanation
Retail on-net fixed voice	Voice calls between two fixed-line subscribers of the modelled operator
Outgoing off-net fixed voice (includes FOAS)	Voice calls from a fixed-line subscriber served by the modelled operator to another subscriber (e.g. domestic mobile operator, any fixed operator, non-geographic number, international destination)
Incoming fixed voice (FTAS)	Voice calls received from any other operator and terminated to a fixed-line subscriber of the modelled operator

3 Model implementation

This section discusses the following aspects of the model implementation:

- Section 3.1 describes the market-related calculations
- Section 3.2 describes the radio network design calculations
- Section 3.3 describes the core network design calculations
- Section 3.4 describes the network expenditure calculations
- Section 3.5 describes the service costing calculations.

3.1 Market calculations

The new cost model uses ACCC data on the total market in Australia, collected from stakeholders under the record keeping rules (RKR). This is supplemented by information provided by Australian mobile and fixed network operators, data collected as part of the 2020 MTAS cost modelling process, and market data from Analysys Mason's Research team. Data inputs are used to drive the forecasts for both market subscribers and traffic. This market information is then rearranged to suit the service categories used in the model itself. Voice, SMS and data traffic are treated separately.⁹ Voice and SMS are split into sub-categories: *incoming*, *outgoing* and *on-net* traffic. All three are also split into the different radio technologies used. An outline of the market calculations is shown in Figure 3.1.

⁹ SMS has very little impact on the mobile network deployment.

Figure 3.1: Overview of market demand forecasting [Source: Analysys Mason, 2025]

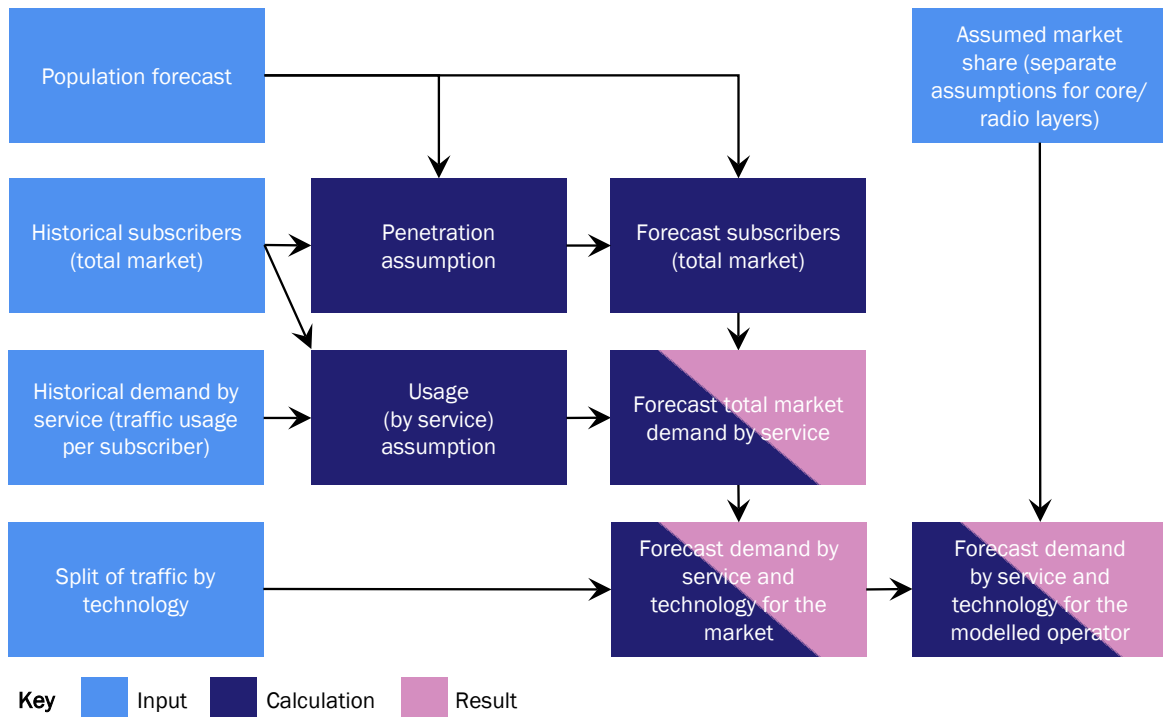

In this section, we outline elements of the market calculations taking place in the *InMkt* worksheet, covering:

- population and subscribers
- voice minutes
- messages
- data volumes.

3.1.1 Population and subscribers

Our population time series is based on data published by the ABS. Historical estimated resident population figures up to December 2024 are sourced from the “National, state and territory population” dataset.¹⁰ Projections for future years are taken from the medium series of ABS’s population projections, which uses a 2022 base year and extends to 2071.¹¹ Our population forecast, shown in Figure 3.2 below, reaches 32.4 million people by 2040, and 39 million by 2070. We will revisit these forecasts when finalising the new model should ABS issue updated versions.

¹⁰ See series ID A2060842F; <https://www.abs.gov.au/statistics/people/population/national-state-and-territory-population/sep-2024#data-downloads>

¹¹ See <https://www.abs.gov.au/statistics/people/population/population-projections-australia/latest-release#data-explorer-datasets>

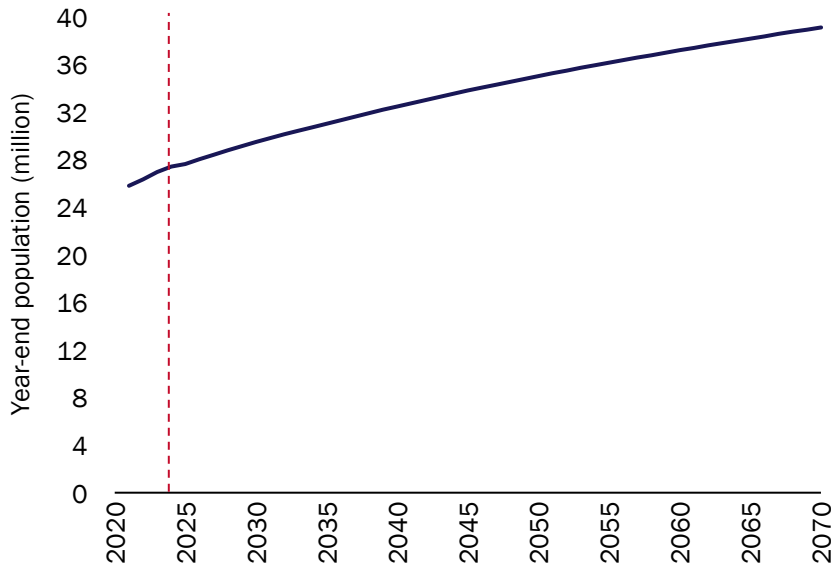

Figure 3.2: Population forecast for Australia [Source: ABS, 2025]

Evolution in Services in Operation (SIOs) over the modelling period serves as a key driver for forecasting traffic across the different services modelled. Historical SIO data, sourced from RKR operator reporting, is used to calculate market penetration. From the final year of available data, a static penetration rate is assumed for the remainder of the modelling period, allowing subscriber numbers to grow in line with total population growth. The penetration levels for the different subscriber categories used are illustrated in Figure 3.3 below.¹²

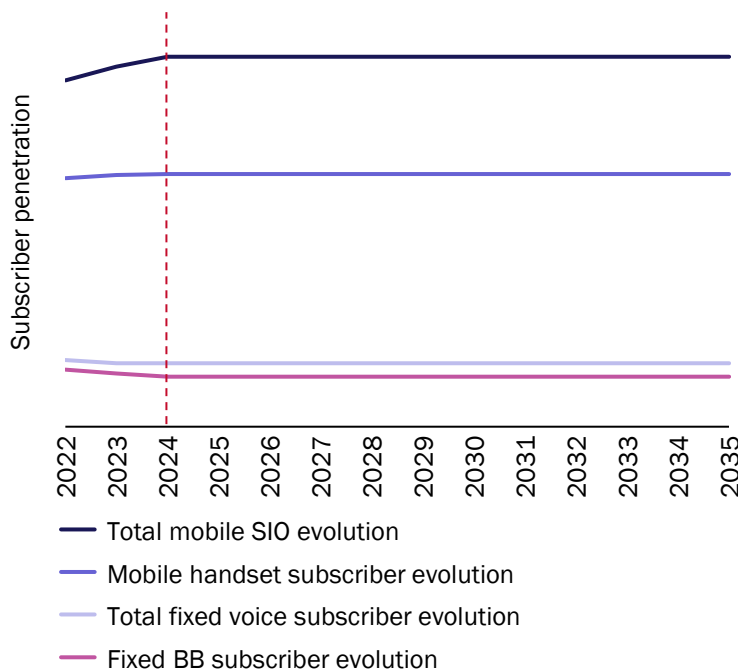

Figure 3.3: Subscriber penetration evolution in Australia [Source: ACCC and Analysys Mason, 2025]¹³

¹² Total mobile SIOs includes mobile handsets, mobile broadband, M2M and home wireless subscriptions, as per the RKR data.

¹³ The RKR reporting gives fixed broadband service in operation (SIO) and data download traffic by retail service provider. When building the market-level picture for fixed data, we have only considered retail subscribers and traffic for the largest operators.

3.1.2 Voice minutes

Mobile voice

Historical total mobile voice traffic and mobile handset subscribers from 2019 to 2023 are used to derive a forecast for the duration of the model. Usage per subscriber is projected using growth rate assumptions and inputs from the market forecasts produced by Analysys Mason’s research and insights team. From 2035 onwards, usage is assumed to have reached a steady state. This evolution is shown in Figure 3.4.

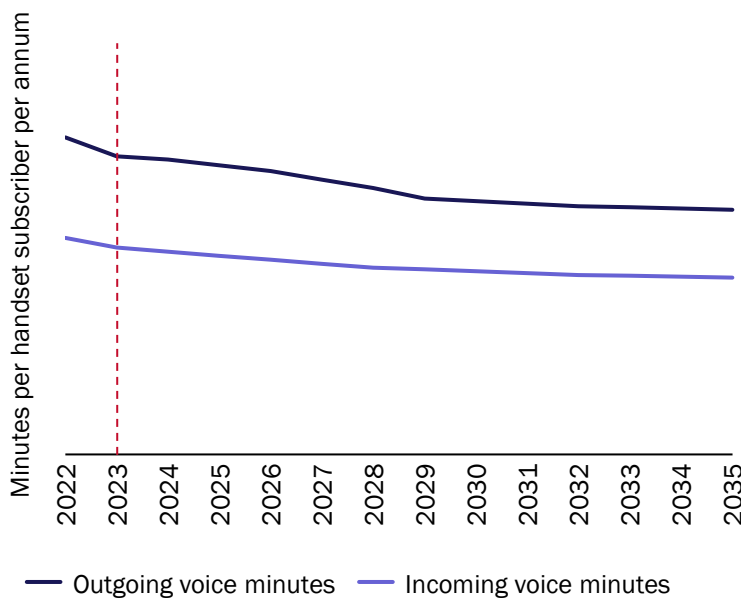

Figure 3.4: Evolution of mobile voice usage in Australia [Source: ACCC and Analysys Mason, 2025]

Based on the mobile voice traffic by user and the assumption that mobile handset subscriber penetration remains constant from 2024 onwards, we calculate total mobile voice traffic for on-net, outgoing off-net and incoming off-net voice.¹⁴ These three categories are added up in Figure 3.5. Total mobile voice traffic is forecast to rise only in line with population growth from 2035 onwards.

¹⁴ Note that due to the approach used for operator reporting, on-net minutes are recorded as both outgoing and incoming traffic. To isolate the on-net traffic component, we apply a split based on inputs from the 2020 MTAS cost modelling process.

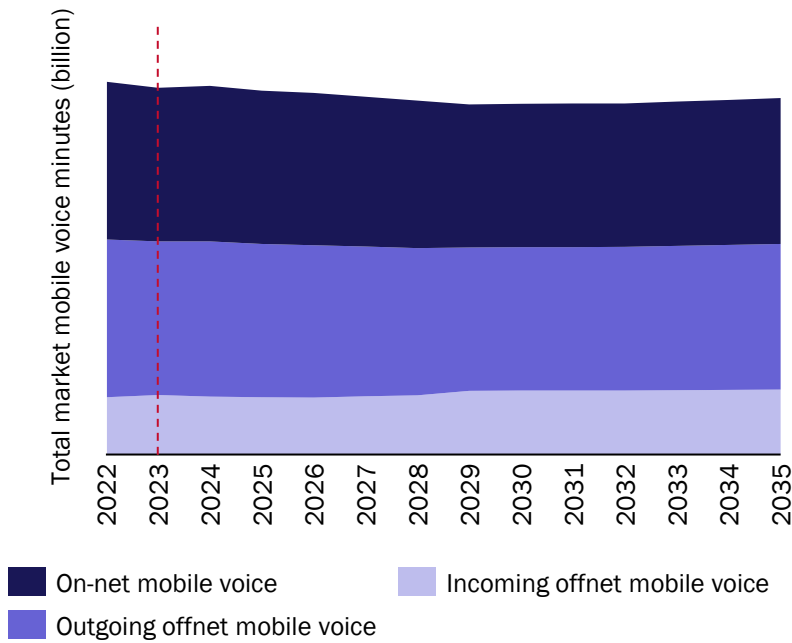

Figure 3.5: Evolution of total mobile voice over mobile networks traffic in Australia [Source: ACCC and Analysys Mason, 2025]

Australia completed the decommissioning of its 3G radio networks in 2024; this is reflected in the voice technology migration profile used in the model. VoLTE is currently the primary platform for delivering mobile voice services in Australia. The model includes the functionality to migrate voice traffic to a VoNR platform as the technology matures. A forecast for VoNR traffic has been included, allowing the ACCC to assess the impact of considering VoNR as a means of delivering the MTAS in the next regulatory period. From 2030 onwards, VoLTE traffic is held constant year on year, with any incremental growth in voice traffic assumed to be carried over VoNR. This is illustrated in Figure 3.6 below.

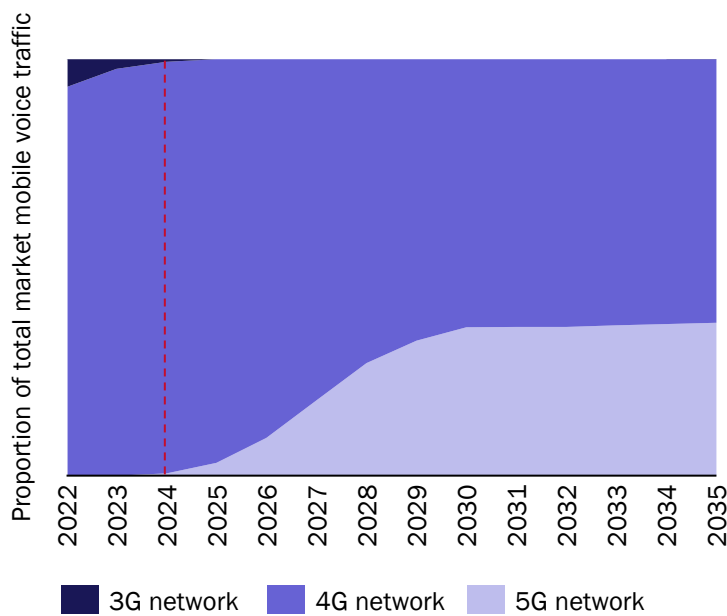

Figure 3.6: Evolution of the share of mobile voice traffic by technology [Source: Analysys Mason, 2025]

Voice over Wi-Fi (VoWiFi)

The model assumes that a portion of mobile voice traffic is delivered via VoWiFi, with these services having routing factors that only use the core network assets. As MNOs were unable to provide specific information on VoWiFi traffic, we used market data from Analysys Mason’s research and insights team to estimate the share of mobile voice minutes attributable to VoWiFi. This portion was then applied as an uplift factor to the forecast mobile voice traffic volumes expected to be carried over the RAN (since our understanding is that the voice volumes recorded by the ACCC do not include VoWiFi). The resulting volumes of VoWiFi are shown in Figure 3.7 below.

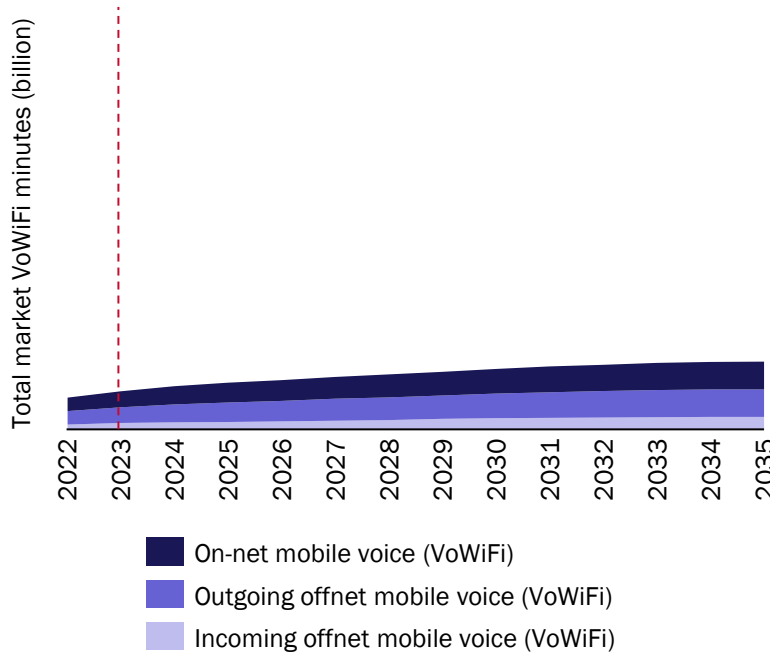

Figure 3.7: Evolution of total VoWiFi traffic in Australia (shown to the same scale as the voice volumes in Figure 3.5 above) [Source: ACCC and Analysys Mason, 2025]

Fixed voice

Historical total fixed voice traffic and fixed voice subscribers from 2018 to 2023 are used to derive a forecast for the duration of the model. Usage per subscriber is projected using growth rate assumptions and inputs from the market forecasts produced by Analysys Mason’s research and insights team. From 2035 onwards, usage is assumed to have reached a steady state. This evolution is shown in Figure 3.8.

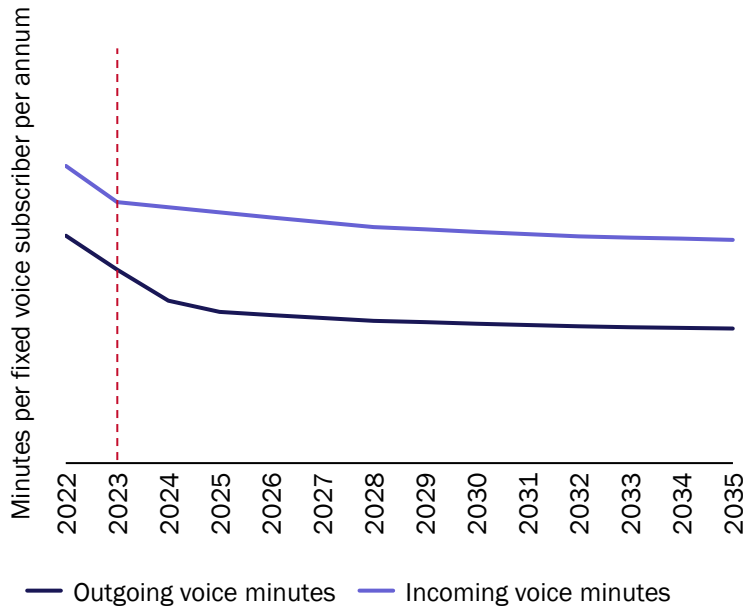

Figure 3.8: Evolution of fixed voice usage in Australia (shown to the same scale as the voice volumes in Figure 3.4 above) [Source: ACCC and Analysys Mason, 2025]¹⁵

Based on the fixed voice traffic by user and the assumption that fixed voice subscriber penetration remains constant from 2023 onwards, we calculate total fixed voice traffic for on-net, outgoing off-net and incoming off-net voice.¹⁶ These three categories are added up in Figure 3.9. Total fixed voice traffic is forecast to rise only in line with population growth from 2035 onwards.

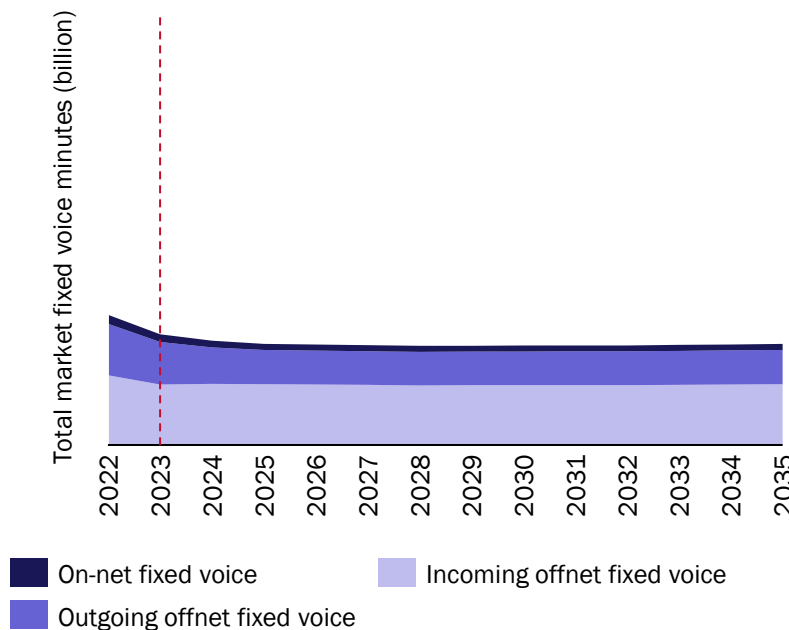

Figure 3.9: Evolution of total fixed voice traffic in Australia (shown to the same scale as the voice volumes in Figure 3.5 above) [Source: ACCC and Analysys Mason, 2025]¹⁵

¹⁵ We note that the RKR was reviewed in 2020 with changes implemented from FY2022. These changes led to an increase in the types of calls captured and reported, resulting in a significant increase between FY2021 and FY2022.

¹⁶ Note that due to the approach used for operator reporting, on-net minutes are recorded as both outgoing and incoming traffic. To isolate the on-net traffic component, we apply a split based on operator inputs.

3.1.3 Messages

The model adopts a similar forecasting approach for SMS as used for voice minutes.

Historical total SMS traffic and mobile subscribers from 2020 to 2022 are used to derive a forecast for the duration of the model. Usage per subscriber is projected using growth rates from the market forecasts produced by Analysys Mason’s research and insights team. From 2035 onwards, usage is assumed to have reached a steady state. This evolution is shown in Figure 3.10.

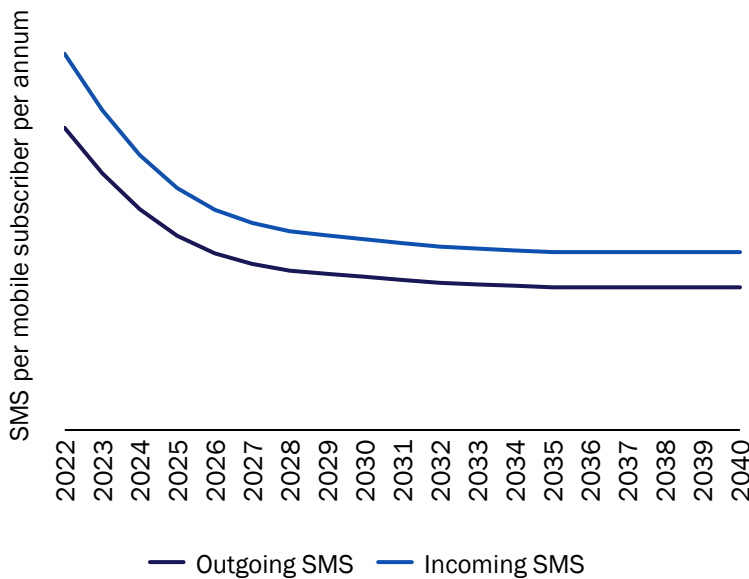

Figure 3.10: Evolution of SMS usage in Australia [Source: ACCC and Analysys Mason, 2025]

Based on the SMS traffic by user and the assumption that mobile subscriber penetration remains constant from 2024 onwards, we calculate total SMS traffic for on-net, outgoing off-net and incoming off-net SMS.¹⁷ These three categories are added up in Figure 3.11. Total SMS traffic is forecast to rise only in line with population growth from 2035 onwards.

¹⁷ Note that due to the approach used for operator reporting, on-net SMSs are recorded as both outgoing and incoming traffic. To isolate the on-net traffic component, we apply a split based on inputs from the 2020 MTAS cost modelling process.

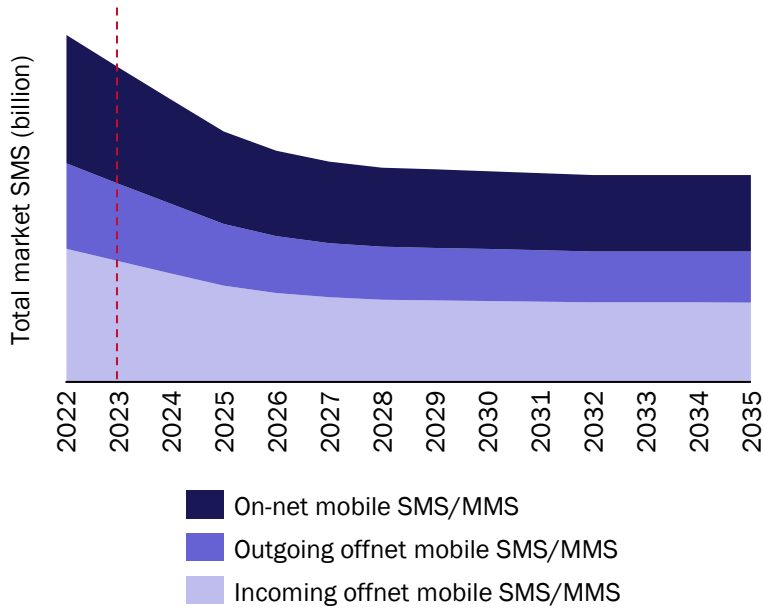

Figure 3.11 Evolution of total SMS traffic in Australia [Source: ACCC and Analysys Mason, 2025]

The SMS traffic forecast in the model follows the same technology migration profile as voice services, as illustrated in Figure 3.6 above.

3.1.4 Data volumes

Mobile data

Historical mobile data download traffic and mobile subscribers from 2019 to 2024 are used to derive a forecast for the duration of the model. Usage per subscriber is projected using growth rates from the market forecasts produced by Analysys Mason’s research and insights team. From 2035 onwards, usage is assumed to have reached a steady state. This evolution is shown in Figure 3.12 below.

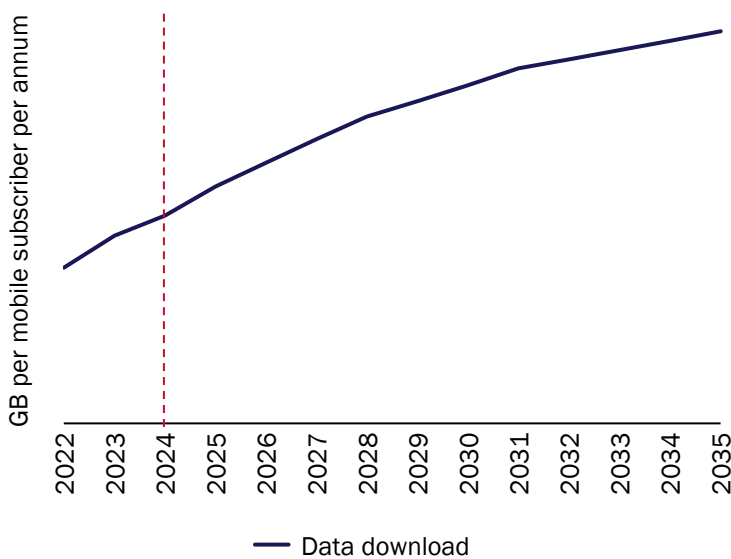

Figure 3.12: Evolution of mobile data usage in Australia [Source: ACCC and Analysys Mason, 2025]

Total mobile data download traffic is calculated based on usage per subscriber, assuming mobile subscriber penetration remains constant from 2024 onwards. Total mobile data upload traffic is then calculated using data inputs from operators, and splits from the 2020 MTAS cost modelling process. These two categories are added up in Figure 3.13. Total mobile data traffic is forecast to rise only in line with population growth from 2035 onwards.

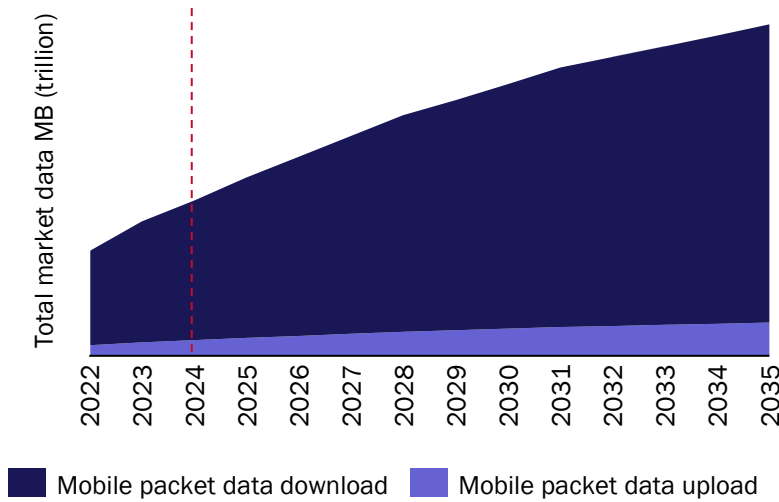

Figure 3.13 Evolution of total mobile data traffic in Australia [Source: ACCC and Analysys Mason, 2025]

This significant increase in volume on a year-to-year basis leads to a corresponding increase in the number of sites and base stations, as no new spectrum is made available in the model over time. This approach regarding forecast spectrum availability is a standard approach in regulatory costing so as not to preclude future market developments.

Based on operator data submitted during the 2020 MTAS cost modelling process, 4G accounted for almost 95% of the total mobile data traffic in 2019. Since then, operator inputs indicate a steady rise in 5G usage for mobile data services over the past four years. The migration trajectory for 5G used in the model mirrors the initial adoption curve of 4G. From 2030 onwards, 4G data traffic is held constant year on year, with any incremental growth in data traffic assumed to be carried over 5G. This is illustrated in Figure 3.14 below.

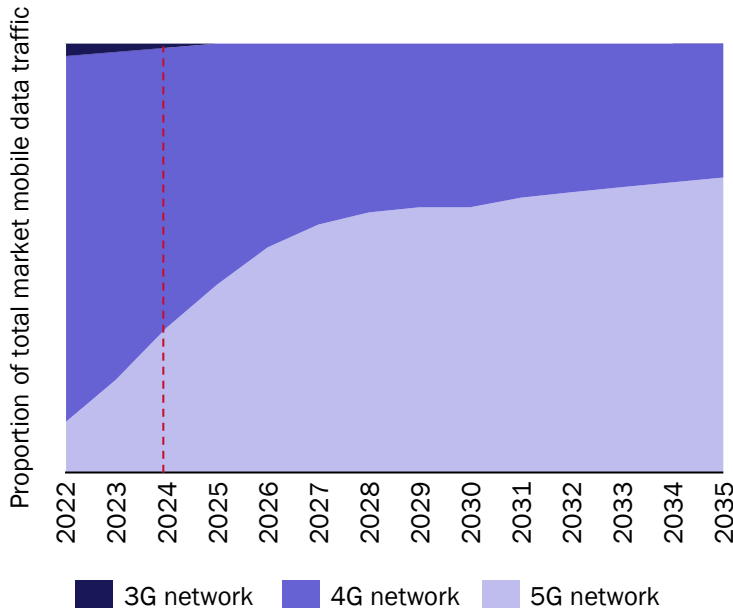

Figure 3.14: Evolution of the share of mobile data traffic by technology [Source: Analysys Mason, 2025]

Fixed data

Historical data download traffic and fixed broadband (FBB) subscribers from 2019 to 2024 are used to derive a forecast for the duration of the model. Usage per subscriber is projected using growth rates from the market forecasts produced by Analysys Mason’s research and insights team. From 2035 onwards, usage is assumed to have reached a steady state. This evolution is shown in Figure 3.15.

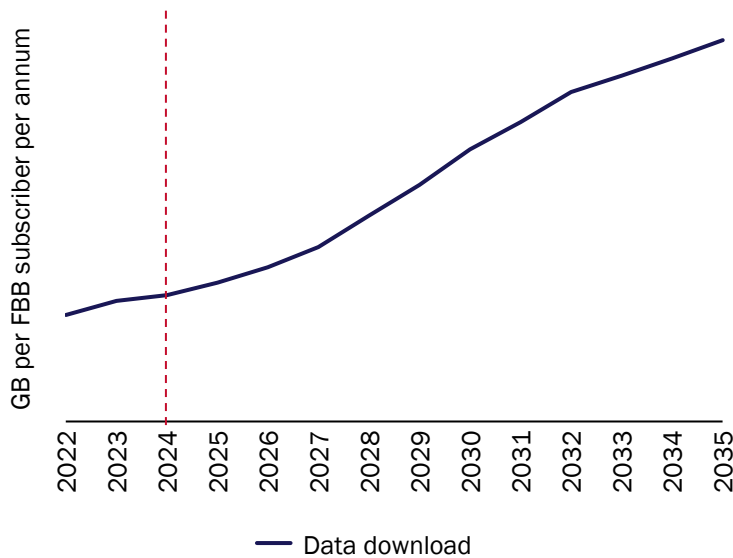

Figure 3.15: Evolution of fixed data usage in Australia [Source: ACCC and Analysys Mason, 2025]

Total fixed data download traffic is calculated based on usage per subscriber, assuming FBB subscriber penetration remains constant from 2024 onwards. Total fixed data upload traffic is then calculated using data inputs from Analysys Mason’s research and insights team. These two categories are added up in Figure 3.16. Total fixed data traffic is forecast to rise only in line with population growth from 2035 onwards.

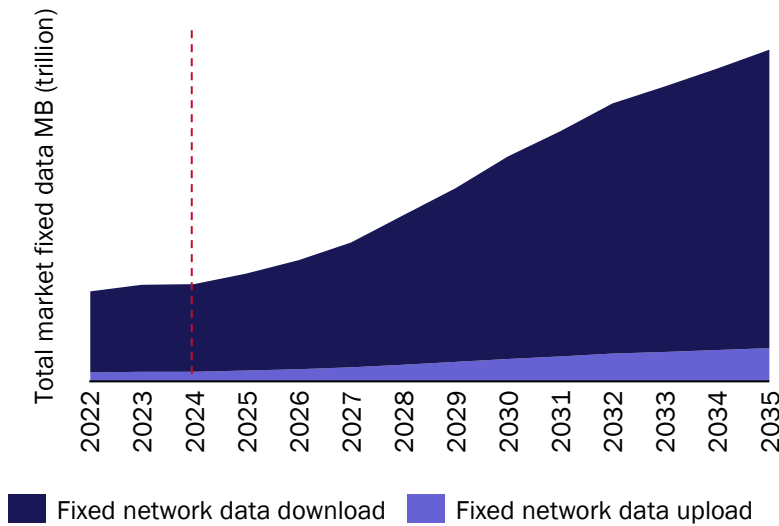

Figure 3.16 Evolution of total fixed data traffic in Australia [Source: ACCC and Analysys Mason, 2025]

3.1.5 Market share

There are three relevant assumed market shares for the modelled operators:

- market share in the mobile radio network
- market share in the mobile core network
- market share in the fixed core network.

Mobile radio

In the case of mobile radio networks, for any given area in our modelled network, there can be either 1, 2 or 3 national operators present. The average value of N has been calculated for each geotype as a population-weighted average, based on the coverage maps of all three national operators. This analysis is described further in Annex B. The calculated market share by geotype is shown below. We show the values for two scenarios: including and excluding the assumed coverage for the Optus/TPG Telecom network share that uses multi-operator core network (‘MOCN’) technology.

Figure 3.17: Market share by geotype [Source: Analysys Mason, 2025]

Geotype	Market share (including Optus/TPG Telecom MOCN)	Market share (excluding Optus/TPG Telecom MOCN)
Major Cities: Very high density	33.3%	33.3%
Major Cities: High density	33.3%	33.3%
Major Cities: Medium density	33.4%	33.3%
Major Cities: Low density	34.0%	33.4%
Inner Regional: Medium/high density	39.1%	33.4%
Inner Regional: Low density	42.8%	34.3%
Outer Regional: Medium/high density	40.4%	33.4%
Outer Regional: Low density	47.8%	36.7%
Remote: Higher density	50.0%	34.1%

Geotype	Market share (including Optus/TPG Telecom MOCN)	Market share (excluding Optus/TPG Telecom MOCN)
Remote: Lower density	50.0%	42.2%
Very Remote: Higher density	50.0%	50.0%
Very Remote: Lower density	50.0%	45.3%
Islands	35.4%	34.6%

The impact of the Optus/TPG Telecom MOCN is that there are only two physical radio access networks in large parts of the regional/remote areas of Australia that are assumed to be covered in the model, increasing the market share of the modelled network in those regions.

Mobile core

The market share for the modelled mobile core network will be $1/3 = 33.3\%$, based on our understanding that each of the three national MNOs in Australia has a standalone core network.

Fixed core

The market share for the modelled fixed core network will be $1/5 = 20\%$. This is because, while there are multiple operators offering fixed voice services, the five largest are Optus, Telstra, TPG Telecom, Symbio and Vocus.

3.2 Radio layer

In this section, we outline the assumed radio design, covering:

- radio and aggregation network
- spectrum allocations.

3.2.1 Radio and aggregation network

The mobile network is segmented into three key layers, access (radio), aggregation and backhaul, and supports two radio technologies (4G, 5G). Figure 3.18 sets out the key elements in the mobile network.

Figure 3.18: Illustrative (modelled) mobile network elements [Source: Analysys Mason, 2025]

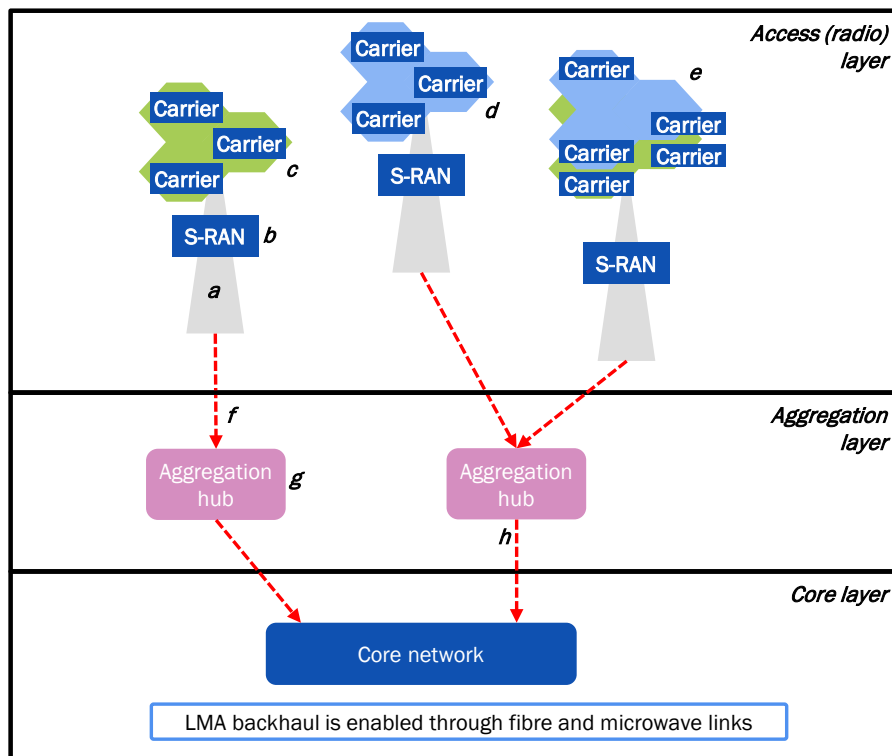

A description of the radio and aggregation layer network elements shown in the diagram is as follows:

- Radio equipment is deployed on rented third-party structures, which can be towers or rooftop installations. The modelled operator incurs a monthly rent for using these physical sites.
- S-RAN units, where all radio access equipment is contained within a single set of electronics.
- 4G carriers have multiple configurations and can be upgraded to carry increasing traffic levels.
- 5G carriers offer greater capacity than 4G carriers, also having multiple configurations and can be upgraded to carry increasing data traffic levels.
- S-RAN equipment can facilitate multiple spectrum bands, and enable deployment of different radio technologies using the same hardware.
- Last-mile access (LMA) backhaul carries traffic from the radio site to an aggregation hub, using a mix of fibre and microwave transmission (and a small fraction can use satellite links in the most remote areas). Microwave transmission links can require multiple hops.
- Aggregation hubs aggregate traffic from multiple radio sites, with a proportion of these hubs co-sited with radio sites).
- Further transmission links carry traffic from the aggregation hubs back to the core network locations, again using a combination of fibre and microwave transmission.

When calculating site counts, we distinguish between towers, rooftop sites and small-cell/indoor sites. The modelled split of LMA backhaul is calibrated to a mix of 85% fibre and 15% microwave (based on top-down information).

3.2.2 Radio spectrum allocations

A large number of spectrum bands are currently in use for mobile networks in Australia. Their key characteristics are summarised below in Figure 3.19. Some bands are used for other purposes, or by companies other than the three national MNOs.

Figure 3.19: Spectrum bands relevant to the model [Source: Analysys Mason, 2025]

Band	Range (MHz)	Type	FDD/TDD ¹⁸	Total MHz
700MHz	703–748/758–803	National	FDD	2×45
850MHz (expansion)	814–825/859–870	National	FDD	2×11
850MHz (original)	825–845/870–890	Regional	FDD	2×20
900MHz	890–915/935–960	National	FDD	2×25
1800MHz	1710–1785/1805–1880	Regional	FDD	2×75
2.1GHz	1920–1980/2110–2170	Regional	FDD	2×60
2.3GHz	2302–2400	Regional	TDD	1×98
2.5GHz	2500–2570/2620–2690	National	FDD	2×70
3.4GHz	3400–3575	Regional	TDD	1×175
3.6GHz	3575–3700	Regional	TDD	1×125
3.7GHz	3700–3800	Regional	TDD	1×100
26GHz	25 100–27 500	Regional	TDD	1×2400

ACMA has released and licensed additional spectrum, designated as area-wide apparatus licences (AWLs).¹⁹ We consider these AWL spectrum allocations to fall outside the scope of the model.

Our assumed MHz allocations are set out by band in Figure 3.20. Values assumed in the 2020 MTAS cost modelling are shown in bold. The new allocations are based on the average MHz allocated per licence across the three national MNOs and were set out in the model specification paper. The allocation assumed in certain bands outside of the metro areas have been reduced e.g. in the 3.7GHz band to reflect the smaller quantity of spectrum currently available to the national MNOs.

Band	Assumed technology	Assumed MHz across the licensed regions
700MHz	4G	2×10
850MHz (expansion)	n/a	0
850MHz (original)	5G	2×5
900MHz	5G	2×10
1800MHz	4G	2×15
2.1GHz metro	4G/5G	2×10
2.1GHz regional	5G	
2.3GHz	5G	0

Figure 3.20: Assumed allocations by band [Source: Analysys Mason, 2025]

¹⁸ Frequency division duplex/time division duplex.

¹⁹ See the announcement by ACMA [here](#).

2.5GHz	4G	2×20
3.4GHz metro	5G	1×30
3.4GHz regional	5G	1×10
3.6GHz	5G	1×40
3.7GHz metro/inner regional	5G	1×40
3.7GHz outer regional/remote	5G	1×10
26GHz	5G	1×750

The model allows for sensitivity testing of the assumed spectrum allocations. It also incorporates additional splits within certain bands to reflect geographical variations in spectrum availability for MNOs. This allow, for example, to distinguish between 2.1GHz metro and 2.1GHz regional allocations.

The maximum population coverage of each spectrum band has been calculated by geotype based on the spectrum licence area definitions from ACMA. For each geotype (and separately for 4G and 5G), the model further cross-checks the assumed maximum population coverage of the spectrum holdings ('X') versus the modelled long-term network population coverage for the technology it is being used for ('Y'), by calculating the ratio $R=X/Y$. If $R<1$, then the radio capacity of the spectrum band (in Mbit/s) is multiplied by the ratio R to reflect the fact that the spectrum cannot be used in all areas of the geotype covered by the network to provide capacity. The model currently has no geotypes for either 4G or 5G where the ratio for a used spectrum band is below 0.75.²⁰

An allocation for the 2.3GHz band is not included by default since, to our understanding, it is only used in a limited fashion for mobile networks in Australia (by one operator in metro areas). However, the model tests the impact of including an allocation of this band as additional spectrum holdings (assumed to be a 98MHz allocation limited to the major cities).

3.3 Core layer

In this section, we outline the assumed core network design, covering:

- assumed location of core network nodes
- transmission links between core network nodes
- modelled voice platform.

²⁰ One example is the 1800MHz band, where the band is available for 100% of population in geotypes 1–6 (metro/inner regional geotypes) but only covers 87% of geotype 7 and 93% of geotype 8 (outer regional geotypes). 1800MHz is used for the 4G network in the model, but the long-term 4G coverage for geotype 7 is 98% and 57% for geotype 8. Therefore, there could be an issue in geotype 7 (where 1800MHz cannot be used for capacity at some sites in the geotype). The ratio 87%/98% is 0.89. The assumed 4G capacity (in Mbit/s) of the 1800MHz band in geotype 7 has been multiplied by 0.89. This drives slightly more capacity sites to reflect the use of other bands in cases where 1800MHz spectrum cannot be used.

3.3.1 Assumed node locations

We have assumed that there are two core network locations in each of the eight states/territories in Australia. We have used the centroids of high population density SA2 areas in those states to simulate the locations. We think this is a reasonable approximation given the significant distances between the core network locations. These locations are set out below in Figure 3.21.

State	No.	SA2 code	SA2 name
ACT	1	801061131	Kingston (ACT)
ACT	2	801051051	Braddon
NSW	1	117031645	Sydney (South) - Haymarket
NSW	2	117031647	Waterloo
NT	1	701021025	Nightcliff
NT	2	701021028	Wagaman
QLD	1	305011106	Fortitude Valley
QLD	2	305011105	Brisbane City
SA	1	401071024	Unley - Parkside
SA	2	401051017	Norwood (SA)
TAS	1	601051031	Sandy Bay
TAS	2	601051033	West Hobart
VIC	1	206041504	Melbourne CBD - North
VIC	2	206041509	Southbank - East
WA	1	503021296	Perth (North) - Highgate
WA	2	503021295	East Perth

Figure 3.21: Assumed core network locations
[Source: Analysys Mason, 2025]

3.3.2 Transmission links

We have designed a resilient core network transmission ring for these locations, with the two locations in each state connected to the two locations in the next state. We illustrate the assumed links in Figure 3.22 below, with a closer view of the links between the locations in the Australian Capital Territory (ACT), Victoria (VIC), Southern Australia (SA) and Tasmania (TAS).

Figure 3.22: Assumed core network architecture [Source: Analysys Mason, 2025]

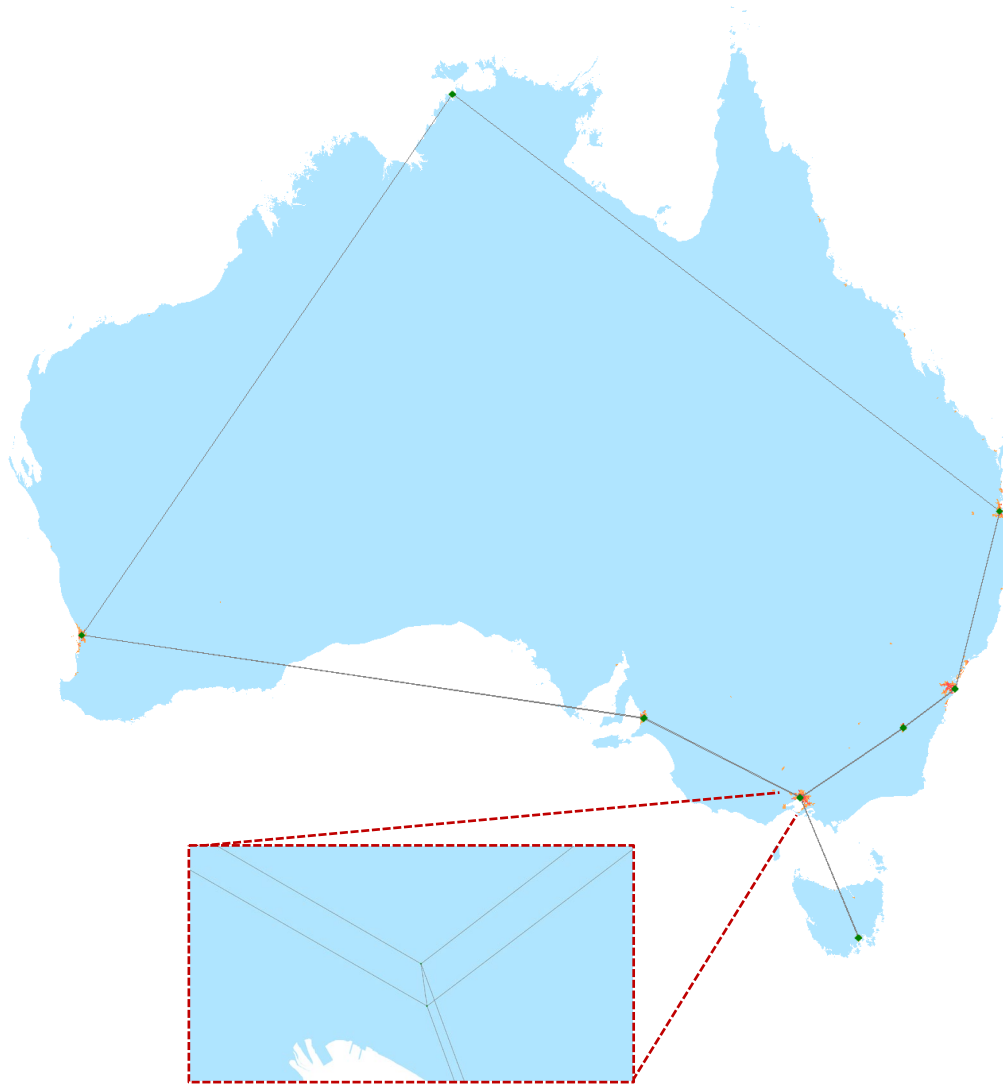

3.3.3 Voice platform

We have modelled an IMS core to switch and route the modelled voice traffic between core network locations. A diagram of the architecture for the modelled mobile network is shown below in Figure 3.23 (acronyms are expanded in Annex A).

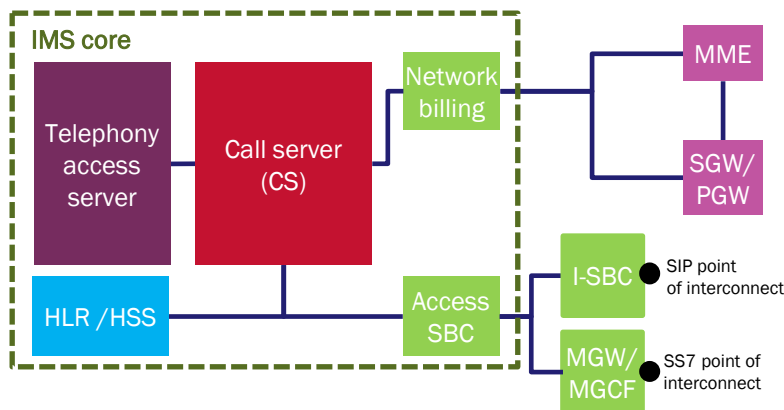

Figure 3.23: Assumed voice platform architecture [Source: Analysys Mason, 2025]

The IMS core is also used as the basis for the modelled fixed core network to provide fixed voice-over-IP (VoIP) services. This is a platform dedicated to voice services and therefore should be recoverable only by voice services, through the principle of cost causation.

We have modelled a 5G standalone core, since our understanding is that all three national MNOs in Australia have deployed, or are in the process of deploying, this 5G core network technology.²¹

The contribution to the FTAS and the FOAS from other parts of the fixed core network is minimal, as usage of these assets by voice traffic is negligible compared to both usage by data traffic and dedicated capacity set aside for transmission services. Therefore, other parts of the fixed core network (including inter-node infrastructure and other switching/routing equipment) are not modelled explicitly.

3.4 Network expenditure

In this section, we outline the cost assumptions made for the model. We describe assumptions related to capital expenditure, operating expenditure, cost trends, lifetimes, spectrum fees, overheads and the assumed WACC in turn below.

3.4.1 Unit capex

We have derived capex estimates for the following assets based on the data provided by operators.

Figure 3.24: Assets with capex costs derived from operator data [Source: Analysys Mason, 2025]

Asset type	Approach used to derive model inputs
Outdoor sites	<ul style="list-style-type: none"> Operators provided capex inputs for different site types (tower/rooftop/ small cells) across different remoteness area types We assume that a proportion of these costs provided reflect site design and preparation (and are still incurred by the operator) To derive an average capex value, a weighted average calculation was used; this considered the number of sites each operator had by site type and area category, ensuring the averages reflect the actual distribution of infrastructure. An example calculation is given below.
Indoor sites	<ul style="list-style-type: none"> An input for indoor site capex was received; indoor capex as a percentage of rooftop capex was calculated and applied to other operator site capex inputs. A simple average for indoor site capex was then calculated across operators.
S-RAN	<ul style="list-style-type: none"> Operators provided capex inputs for the purchase and installation of active equipment on mobile sites. The capex estimates for sites configured with a full stack of 4G and 5G carriers served as the basis for deriving the costs of incremental carrier augmentations (i.e. selection of activated bands). To derive an average capex value for each augmentation level, a weighted average calculation was used; this considered the number of sites each operator had by area category, ensuring the averages reflect the actual distribution of infrastructure.

²¹ See these announcements for [Optus](#), [Telstra](#) and [TPG Telecom](#), respectively.

Asset type	Approach used to derive model inputs
Transmission links	<ul style="list-style-type: none"> Operators provided installation capex data for LMA backhaul links. A simple average by link type was calculated.
Core network equipment	<ul style="list-style-type: none"> Operators provided capex data for core network equipment. A simple average by equipment type was calculated.

An example weighted average calculation for the asset “Major Cities – site – rooftop” is given below. In this example, dummy data is used.

Calculation steps:

1. Aggregate operator unit capex inputs for rooftop sites in major cities:

Site type	Area type	Installation unit capex (2024) – Operator 1	Installation unit capex (2024) – Operator 2	Installation unit capex (2024) – Operator 3
Rooftop site	Major cities	300 000	250 000	350 000

2. Aggregate operator site counts for rooftop sites in major cities:

Site type	Area type	Site count – Operator 1	Site count – Operator 2	Site count – Operator 3
Rooftop site	Major cities	1000	2000	2500

3. Unit capex is multiplied by site count to calculate total capex per operator:

Site type	Area type	Site count × unit capex – Operator 1	Site count × unit capex – Operator 2	Site count × unit capex – Operator 3
Rooftop site	Major cities	300 000 000	500 000 000	875 000 000

4. A weighted average calculation in which total capex is summed across the operators and divided by total site count:

$$1\,675\,000\,000 / 5500 = 304\,545$$

5. The weighted average result is rounded to two significant figures and used as model input: AUD 300 000.

3.4.2 Opex

In the model, unit opex is either calculated as a proportion of capex, or as a fixed amount derived from operator inputs (where available). We have included fixed unit opex inputs for the following assets based on the data provided by operators.

Figure 3.25: Assets with opex costs derived from operator data [Source: Analysys Mason, 2025]

Asset type	Approach used to derive model inputs
Outdoor site rental ²²	<ul style="list-style-type: none"> Operators provided rental opex inputs for different site types (tower / rooftop / small cells) across different remoteness area types. To derive an average rental opex value, a weighted average calculation was used; this considered the number of sites each operator had by site type and area category, ensuring the actual distribution of infrastructure is reflected.
Outdoor site power	<ul style="list-style-type: none"> Operators provided power opex inputs for different site types (tower / rooftop / small cells) across different remoteness area types. To derive an average power opex value, a weighted average calculation was used; this considered the number of sites each operator had by site type and area category, ensuring the actual distribution of infrastructure is reflected.
Indoor sites	<ul style="list-style-type: none"> An input for indoor site opex was received; indoor opex as % of rooftop opex was calculated and applied to other operator site opex inputs. A simple average for indoor site opex was calculated across operators
Transmission links	<ul style="list-style-type: none"> Operators provided opex data for LMA backhaul links. A simple average by link type was calculated.
Core network equipment	<ul style="list-style-type: none"> Operators provided opex data for core network equipment. A simple average by equipment type was calculated.

3.4.3 Cost trends

The model includes assumptions of time series of capital cost trends and operating cost trends. These are expressed in real-terms currency and are located on the *InCostTrend* worksheet. These inputs parameterise how the unit capex/opex of an asset evolves over time. The assumed values, based on benchmarks from other cost models, are shown in Figure 3.26 below.

Cost type	Category	Real-terms trend
Capex	Radio sites (all types)	+0% in all years
Capex	Fibre backhaul	-2% in all years
Capex	Microwave backhaul	+1% in all years
Capex	S-RAN equipment	-5% in all years
Capex	Other transmission	+0% in all years
Capex	Mobile/fixed core network equipment	-5% in all years
Opex	All assets	+0% in all years

Figure 3.26:
Assumed cost trends [Source: Analysys Mason, 2025]

The impact of using a real-terms opex cost trend of 0% for all assets is that the opex is recovered in net present value terms according to the time series of service demand.

²² Note that operating expenditure (opex) for rental and power is treated as separate cost components for tower and rooftop sites. However, for indoor and small cell sites, these costs are combined into a single opex payment.

3.4.4 Lifetimes

The model includes economic lifetimes that determine how frequently network assets are replaced (and therefore incur replacement capex). These inputs are specified on the *InAsset* worksheet and used for the replacement algorithm on the *NwDeploy* worksheet. The assumed values are shown in Figure 3.27 below.

Assets	Economic lifetime (years)
Site ancillary and preparation (both radio and core sites)	10
Most electronic equipment (both S-RAN and core-related)	8
SMSC/MMSC, voice platform servers and billing systems	6
Transmission links and equipment	5
Session border controllers, other IT	3

Figure 3.27:
Assumed lifetimes
[Source: Analysys
Mason, 2025]

3.4.5 Spectrum fees

The model allocates spectrum costs calculated based on the assumed spectrum holdings for the modelled operator. Spectrum fees are calculated on a year-by-year basis. Fees are calculated by band and then mapped onto 4G and 5G technology. The key aspects of this approach are set out below.

Figure 3.28: Main aspects to modelling spectrum costs [Source: Analysys Mason, 2025]

Aspect of approach	Description of approach
One-off payments (modelled as capex)	<ul style="list-style-type: none"> Historical auction payments for active licences Renewal fees
Recurring payments (modelled as opex)	<ul style="list-style-type: none"> Spectrum licence tax (SLT) main component Fees for the Enhanced Electromagnetic Energy (EME) programme
Depreciation method	Economic depreciation
Allocation key	Radio traffic of the modelled operator, based on the demand forecasts
Allocation approach	Allocate spectrum costs to the traffic of the network technologies using the spectrum e.g. if a spectrum band is assumed to be used only for 4G traffic, then its costs are allocated only to 4G traffic

The following assumptions are made in the model:

- all licences that have expired in or before 2024 will be assumed to have been fully recovered
- 900MHz spectrum fees no longer apply following the 2021 auction of the 850MHz expansion and 900MHz bands: these past costs will be assumed to have been fully recovered
- the economic depreciation calculation for spectrum cost allocation uses an extended timeframe to capture demand since the start of current active licence. Demand for the years up to 2019 is calculated based on RKR operator inputs and data from the 2020 MTAS cost modelling process.

One-off payments (modelled as capex)

Historical capex payments for active licences are calculated by spectrum band, using data from relevant allocation processes (i.e. spectrum auctions and licence renewals). A market-level MNO fee (AUD/MHz/pop) is derived and applied to the spectrum holdings of the hypothetical operator. This calculation uses the following sources:

- ACMA spectrum auction information,²³ including:
 - Spectrum Marketing Plans, which detail the MHz lots available and the geographical areas covered (by hierarchical cell identification scheme (HCIS) references)
 - auction results, including revenue raised.
- ACMA’s Register of Radiocommunication Licences, which provides current licence holdings and licensee information²⁴
- Pricing Directions and resulting Spectrum Access Charge Determinations, which specify AUD/MHz/pop charge applicable for licence renewal across different bands.²⁵

To derive spectrum costs, total population coverage for each band has been calculated using HCIS references from the Spectrum Marketing Plans and licence documentation, combined with ACMA census population data by HCIS Identifier.

The model assumes that the hypothetical operator’s spectrum licences are renewed throughout the modelling period. ACMA’s draft proposal regarding the renewal of multiple expiring spectrum licences (ESLs) between 2028 and 2032 is captured in the draft new cost model, using the midpoint of the proposed spectrum price ranges.²⁶ Provided ACMA’s final approach is available, these inputs will be reflected in the final cost model. A sensitivity test assuming the upper bound of each spectrum price range is also included.

The table below summarises the approach used for calculating historical and future spectrum capex payments for each band.

Figure 3.29: Capex payment assumptions for spectrum holdings of the hypothetical operator in the model [Source: Analysys Mason, 2025]

Band	Assumed MHz holdings	Historical capex payments	Future capex payments
700MHz	2×10	2×5 acquired at the 2013 700MHz (Digital Dividend) auction	Licence renewal price and duration in line with the ACMA ESL proposal, with 15-year licence renewals at the same price

²³ See <https://www.acma.gov.au/spectrum-auctions>

²⁴ See https://web.acma.gov.au/rrl/browse_licences.cat_listing

²⁵ Accessible here: [https://www.legislation.gov.au/search/text\(%22Spectrum%20access%20charges%22,name,all\)/pointintime\(Latest\)/sort\(searchcontexts%252Ftext%252Frelevance%2520desc\)](https://www.legislation.gov.au/search/text(%22Spectrum%20access%20charges%22,name,all)/pointintime(Latest)/sort(searchcontexts%252Ftext%252Frelevance%2520desc))

²⁶ See <https://www.acma.gov.au/expiring-spectrum-licences>

Band	Assumed MHz holdings	Historical capex payments	Future capex payments
		2x5 acquired at the 700MHz 2017 residual lots auction	thereafter (normalised for licence duration)
850MHz (expansion)	0	Holdings acquired at the 2021 850/900MHz bands auction	15-year licence renewals at the price specified for the original 850MHz band in the ACMA ESL proposal (normalised for licence duration)
850MHz (original)	2x5	Holdings renewed in 2013 at renewal price	Licence renewal price and duration per the ACMA ESL proposal, with 15-year licence renewals thereafter (normalised for licence duration)
900MHz	2x10	Holdings acquired at the 2021 850/900MHz bands auction	15-year licence renewals at the price specified for the original 850MHz band in the ACMA ESL proposal (normalised for licence duration)
1800MHz	2x15	2x10 in metro areas renewed in 2013 at renewal prices 2x5 in metro areas renewed in 2015 at renewal prices 2x5 in regional areas renewed in 2013 at renewal prices 2x10 in regional areas acquired at the 1800MHz Regional auction in 2016/residual lots auction in 2017	Licence renewal price and duration in line with the ACMA ESL proposal, with 15-year licence renewals at the same price thereafter (normalised for licence duration)
2.1GHz metro	2x10	Holdings renewed in 2017 at renewal price	
2.1GHz regional			
2.3GHz	0	Holdings renewed in 2015 at renewal price	
2.5GHz	2x20	Holdings acquired at the 2013 2.5GHz band reallocation auction	
3.4GHz metro	1x30	Due to the complexity of MNO holdings in the 3.4GHz band, it is assumed that the hypothetical operator's current licence began in 2015 for a 15-year duration (in line with the last renewal process) A rounded, weighted average AUD/MHz/pop price is used, based on prices paid by MNOs in the 2015 renewal process and subsequent auctions in	
3.4GHz regional			

Band	Assumed MHz holdings	Historical capex payments	Future capex payments
		2017 and 2023 (normalised for licence duration)	
3.6GHz	1×40	Holdings acquired at the 2018 3.6GHz auction	
3.7GHz metro/ inner regional	1×40	Holdings acquired at the 2023 3.4GHz/3.7GHz auction	15-year licence renewals at the price specified for the wider 3.4GHz band in the ACMA ESL proposal (normalised for licence duration)
3.7GHz outer regional/remote			
26GHz	1×750	Holdings acquired at the 2021 26GHz auction	15-year licence renewals at the previous auction price (normalised for licence duration)

Recurring payments (modelled as opex)

Annual spectrum opex payments consist of two components: the SLT main component and EME fee. These payments are calculated for the spectrum holdings of the hypothetical operator, following the methodology set out by ACMA.²⁷

3.4.6 Overheads

The model includes mark-ups for non-network common costs (overhead costs). Separate mark-ups are parameterised for capex and opex and have been informed by top-down expenditure submitted by operators.

3.4.7 WACC

The WACC assumed in the model is a real-terms pre-tax WACC of 5.64%. This has been calculated by the ACCC.

3.5 Service costing

In this section, we describe the final steps taken in the model after derivation of network expenditure, namely annualisation of costs and allocation of annualised costs to services.

3.5.1 Annualisation of capex (depreciation) and opex

The model uses a depreciation method referred to as economic depreciation. This approach applies the principle of recovering efficiently incurred costs in an economically rational way by ensuring

²⁷ <https://www.acma.gov.au/spectrum-licence-taxes>

that the total of the (cost-oriented) revenue generated across the lifetime of the business is equal to the efficiently incurred costs, including cost of capital, in net present value (NPV) terms.

Economic depreciation is applied to separately both capex and opex.

This calculation is carried out for each individual asset class, rather than in aggregate, in order to allow any variation in capex price trends and opex cost trends for each asset class to be reflected.

The calculation of the cost recovered needs to reflect the time value of money. This is accounted for by the application of a discount factor on future cashflows, which is equal to the WACC of the modelled operator.

The business is assumed to be operating in perpetuity, and investment decisions are made on this basis. This means it is not necessary to recover specific investments within a particular time horizon (e.g. the lifetime of a particular asset), but rather throughout the lifetime of the business. This situation is approximated by explicitly modelling a period of 50 years (2020–2070). At the real discount rate applied (which is derived using the WACC), the present value of the cashflows in the last year of the model is very small and thus any perpetuity value beyond 50 years is regarded as immaterial to the final cost result.

The constraint on cost recovery ($\text{NPV of costs} = \text{NPV of output} \times \text{calculated unit costs}$) can be satisfied by (an infinite) number of possible cost-recovery profiles. However, it would be impractical and undesirable from a regulatory pricing perspective to choose an arbitrary or highly fluctuating recovery profile.²⁸ Therefore, we choose a cost-recovery profile that is in line with the revenue generated by the business. In a competitive and contestable market, the revenue that can be generated is a function of the lowest prevailing cost of supporting that unit of demand, thus the price will change in accordance with the costs of the modern equivalent asset (MEA) for providing the service.²⁹ The unit cost is therefore assumed to follow the (MEA) unit asset cost trend for that asset class. The cost-recovery profile for each asset class is the product of the demand supported by the asset (i.e. its economic output) and the MEA unit asset cost trend. This gives a unique solution.

The efficient expenditure of the operator comprises all the operator's efficient cash outflows over the lifetime of the business, meaning that capex and opex are not differentiated for the purposes of cost recovery. Since the model considers all efficient costs incurred over the lifetime of the business, these are assumed to be recovered by cost-oriented revenue over the lifetime of the business. This principle implies that the treatment of capex and opex should be consistent, since they both contribute to supporting the cost-oriented revenue generated over the lifetime of the business.

The PV of the total expenditure is the amount which must be recovered by the revenue stream. The discounting of revenue in each future year reflects the fact that delaying cost recovery from one year

²⁸ For example, because it would be difficult to send efficient pricing signals to interconnecting operators and their consumers with an irrational (but NPV=0) recovery profile.

²⁹ In a competitive and contestable market, if incumbents were to charge a price in excess of that which reflected the MEA prices for supplying the same service, then competing entry would occur and demand would migrate to the entrant which offered the cost-oriented price.

to the next accumulates a further year of cost of capital employed. This leads to the fundamental equation of the economic depreciation calculation that is:

$$PV(\text{expenditure}) = PV(\text{unit cost} \times \text{output})$$

The *unit cost × output* which the operator gains from the service in order to recover its expenditure plus the cost of capital employed is modelled as *output × year 1 unit cost × MEA price index*. This quantity is discounted because it reflects future cost recovery. (Any costs recovered in the years after a network element is purchased must be discounted by an amount equal to the WACC in order that the cost of capital employed in the network element is also returned to the operator.)

- **output** – the service volume carried by the network element
- **MEA price index** – the cumulated input price trend for the network element which proportionally determines the trend of the unit cost that recovers the expenditure (effectively, the percentage change to the cost of each unit of output over time).

This leads to the following general equations:

$$\text{cost recovery (year } n) = \text{unit cost in year } 1 \times \text{output} \times \text{MEA price index}$$

Using the above relationship, the above equation is equal to:

$$PV(\text{expenditure}) = PV(\text{unit cost in year } 1 \times \text{output} \times \text{MEA price index})$$

This equation can be rearranged as follows:

$$\text{unit cost in year } 1 = PV(\text{expenditure}) / PV(\text{output} \times \text{MEA price index})$$

Then, returning to the original equation for cost recovery in year *n*, the yearly price over time is simply calculated as:

$$\text{yearly unit cost over time} = \text{unit cost in year } 1 \times \text{MEA price index over time}$$

This calculation is undertaken separately for the capex and opex components in the model.

3.5.2 Allocation to services

Routeing factors are used to allocate costs calculated by asset between the modelled service volumes in a neutral way. The routeing factors most commonly used in cost models of telecoms networks are average traffic routeing factors. The factors convert all service volumes into an equivalent traffic measure using appropriate technical conversion factors. The (sourced) inputs and derivation of these conversion factors are included in the model.

We convert all modelled service volumes into voice-equivalent minutes, which forms the basis of the allocation.

The demand-weighted asset output will be calculated for each asset and used to split total costs between all service volumes using the formula below:

$$Cost(Service_k) = \sum_{assets} cost_per_unit_output(asset_i) \times RoutingFactor(asset_i, service_k)$$

An example extract from the full routing factor table in *InRF* worksheet is shown in Figure 3.30.

Figure 3.30: Example extract of full routing factor table in the *InRF* worksheet [Source: Analysys Mason, 2025]

Network element	LRAIC+ routing measure	4G on-net mobile voice	4G outgoing offnet mobile voice	4G incoming offnet mobile voice	4G packet data (download)
Major Cities - site - tower	Radio equivalent minutes	2	1	1	0.055308642
Major Cities - site - rooftop	Radio equivalent minutes	2	1	1	0.055308642
Major Cities - site - SMC	Radio equivalent minutes	2	1	1	0.055308642
Major Cities - site - indoor	Radio equivalent minutes	2	1	1	0.055308642
Major Cities - site - tower - power opex	Radio equivalent minutes	2	1	1	0.055308642
Major Cities - site - rooftop - power opex	Radio equivalent minutes	2	1	1	0.055308642
Major Cities - Fibre transmission	LMA IP Mbytes of traffic	0.638671875	0.319335938	0.319335938	1
Major Cities - Owned microwave transmission	LMA IP Mbytes of traffic	0.638671875	0.319335938	0.319335938	1
Major Cities - Leased microwave transmission	LMA IP Mbytes of traffic	0.638671875	0.319335938	0.319335938	1
Major Cities - Satellite transmission	LMA IP Mbytes of traffic	0.638671875	0.319335938	0.319335938	1
Aggregation hubs: Major Cities	LMA IP Mbytes of traffic	0.638671875	0.319335938	0.319335938	1
Hub->core microwave links: Major Cities	LMA IP Mbytes of traffic	0.638671875	0.319335938	0.319335938	1
Hub->core fibre links: Major Cities	LMA IP Mbytes of traffic	0.638671875	0.319335938	0.319335938	1
Core transmission links	Core-core IP Mbytes voice plus data	0.348632813	0.104589844	0.104589844	0.15
Core transmission radial kilometres	Core-core IP Mbytes voice plus data	0.348632813	0.104589844	0.104589844	0.15
MME	LTE data traffic	0	0	0	1
SGW/PGW	LTE data traffic	0	0	0	1
NMS	Subscribers	0	0	0	0
Unused asset 204	No routing	0	0	0	0
Unused asset 205	No routing	0	0	0	0
Mobile number portability (MNP)	Call origination and termination events	1	1	1	0
SMSC/MMSC	Originated SMS	0	0	0	0
Mobile HLR (HSS)	Subscribers	0	0	0	0
Mobile: Call server	VoLTE+VoNR voice traffic	0	0	1	0
Mobile: Telephony access server	VoLTE+VoNR voice traffic	0	0	1	0
Mobile: Network billing	Wholesale minutes	0	1	1	0
Mobile: Access SBCs (A-SBCs)	VoLTE+VoNR voice traffic	0	0	1	0
Mobile: Interconnect SBCs (I-SBCs)	VoLTE+VoNR voice traffic	0	0	1	0
Mobile: Pol	Interconnect traffic	0	1	1	0
Mobile: MGW + MGCF	VoLTE+VoNR voice traffic	0	0	1	0
Mobile: Voice IT	VoLTE+VoNR voice traffic	0	0	1	0

4 Finding and recommendations

This section sets out our findings and recommendations:

- Section 4.1 provides a description of the base case scenario
- Section 4.2 provides a summary of the cost results derived from the model
- Section 4.3 includes an explanation of the sensitivity tests conducted.

4.1 Description of base case

The *Ctrl* worksheet contains several inputs and switches that the user can modify to carry out key sensitivity tests. These switches are summarised below.

<i>Real-terms pre-tax WACC</i>	<ul style="list-style-type: none"> • Allows the user to set the WACC used in the model • The model currently assumes a real-terms pre-tax WACC of 5.64% (this has been calculated by the ACCC).
<i>Real-terms currency year</i>	<ul style="list-style-type: none"> • Allows the user to specify the real-terms currency year used in the model (currently 2025).
<i>Year for starting cost recovery</i>	<ul style="list-style-type: none"> • Allows the user to specify the starting year for cost recovery (currently 2025).
<i>Last year in which new investment is incurred</i>	<ul style="list-style-type: none"> • Allows the user to choose the last year in which new investment is incurred (currently 2060).
<i>Last year of cost recovery</i>	<ul style="list-style-type: none"> • Allows the user to choose the last year of cost recovery (currently 2070).
<i>Last year of migration profile</i>	<ul style="list-style-type: none"> • Allows the user to choose the last year of technology migration in the market demand forecasts (currently 2030) • After this year, 4G voice and 4G data traffic volumes are held constant year on year, with any incremental growth in traffic assumed to be carried over 5G.
<i>Working capital allowance</i>	<ul style="list-style-type: none"> • Allows the working capital allowance to be specified by the user, in terms of number of days (currently assumed to be 30/365 – i.e. one calendar month).
<i>Common cost mark-up (capex)</i>	<ul style="list-style-type: none"> • Allows the user to specify the common cost mark-up for capex (currently 1%, derived from top-down cost information).

- Common cost mark-up (opex)* • Allows the user to specify the common cost mark-up for opex (currently 4%, derived from top-down cost information).
- Market share on mobile core network* • Allows the user to choose the operator market share on the mobile core network (currently 33.3%).
- Market share on fixed core network* • Allows the user to choose the operator market share on the fixed core network (currently 20%).
- Include coverage of the TPG Telecom/Optus MOCN)* • Allows the user to choose whether or not to include the TPG Telecom/Optus MOCN coverage in the network model.
- Include remote highways* • Allows the user to choose whether or not to include coverage of remote highways by the network
 • If TRUE, includes national highways in remote areas. Otherwise, only includes national highways in very remote areas.
- Number of years for 5G coverage to reach parity with 4G* • Allows the user to select the number of years taken for 5G area coverage to reach parity with 4G in selected geotypes (currently 10 years)
 • Parity is reached in specified geotypes only (major cities, inner regional, and high density geotypes)

4.2 Cost results

The results of the model are presented below in Figure 4.1. FTAS and FOAS are assumed to have the same value (due to identical routing factors).

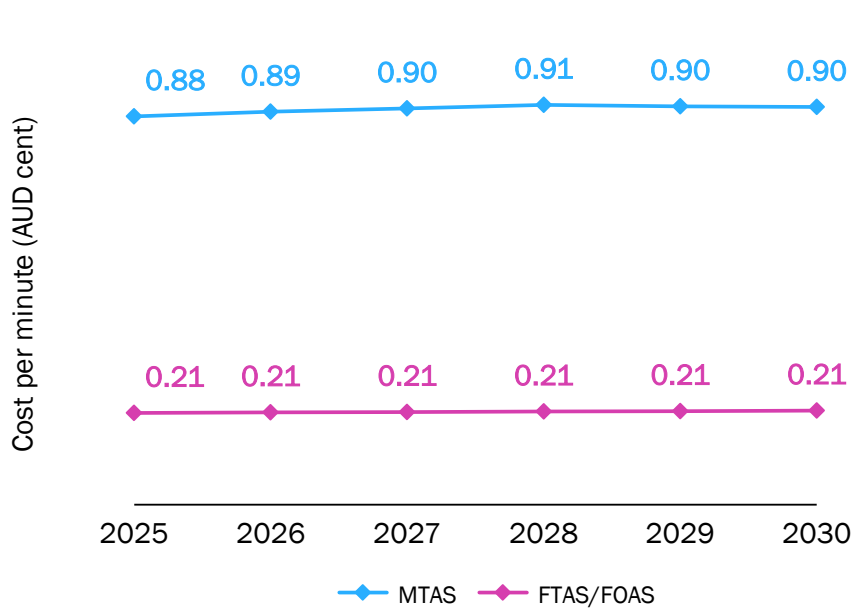

Figure 4.1: Base case results [Source: Analysys Mason, 2025]

4.3 Sensitivity tests

We have defined several sensitivity tests, which are implemented on the *Ctrl* worksheet.

Figure 4.2: Sensitivity tests defined in the model [Source: Analysys Mason, 2025]

Test	Description
Base case	Base case assumptions
[S1] Extended coverage scenario A: geotypes 1–9	Actual area covered by one operator only in geotypes 1–9 is added to the modelled coverage (as is the modelled demand)
[S2] Extended coverage scenario B: all geotypes	Actual area covered by one operator in all geotypes is added to the modelled coverage (as is the modelled demand)
[S3] Exclude impact of MOCN	Use actual coverage of three operators in 2024 as provided
[S4] 25% mobile market share, 15% fixed market share	Market shares of the modelled mobile network and the modelled fixed core network are reduced
[S5] Use of 2.3GHz spectrum in metro areas with base case	An additional 1×98MHz of 2.3GHz spectrum is allocated to the modelled operator in geotypes 1–4 (city areas)
[S6] Use of upper range ACMA spectrum pricing	The upper bound of the spectrum fees (rather than the midpoint) is used to set spectrum prices
[S7] Lower spectrum sensitivity	Assume half the allocation of 900MHz and 2.5GHz spectrum
[S8] Using mix of backhaul more like previous inquiry	A mix of backhaul closer to the split used in the 2020 MTAS cost model is applied
[S9] Assume higher WACC	A higher WACC is set on the <i>Ctrl</i> worksheet
[S10] Assume earlier last year in which new capex is incurred	Assume the final year in which capex is incurred is 2050 rather than 2060

The MTAS results for each sensitivity test are shown below in Figure 4.3.

Figure 4.3: MTAS cost per minute (AUD cent) for sensitivity tests [Source: Analysys Mason, 2025]

Test	2025	2026	2027	2028	2029	2030	Change
Base case	0.88	0.89	0.90	0.91	0.90	0.90	–%
[S1]	0.92	0.93	0.94	0.95	0.94	0.94	+4%
[S2]	0.95	0.96	0.97	0.98	0.98	0.97	+8%
[S3]	0.92	0.94	0.94	0.95	0.95	0.95	+5%
[S4]	1.10	1.12	1.13	1.14	1.14	1.13	+25%
[S5]	0.88	0.89	0.90	0.91	0.91	0.91	+1%
[S6]	0.89	0.90	0.91	0.92	0.91	0.91	+1%
[S7]	0.93	0.94	0.95	0.96	0.96	0.96	+6%
[S8]	0.88	0.89	0.90	0.91	0.90	0.90	–%
[S9]	0.91	0.92	0.93	0.94	0.94	0.94	+4%
[S10]	0.87	0.88	0.89	0.90	0.90	0.90	–1%

The FTAS (and also FOAS) results for each sensitivity test relevant to these services are shown below in Figure 4.4.

Figure 4.4: FTAS/FOAS cost per minute (AUD cent) for sensitivity tests [Source: Analysys Mason, 2025]

Test	2025	2026	2027	2028	2029	2030	Change
Base case	0.21	0.21	0.21	0.21	0.21	0.21	-%
[S4]	0.28	0.28	0.28	0.28	0.28	0.28	+33%
[S9]	0.21	0.21	0.21	0.21	0.22	0.22	+1%
[S10]	0.21	0.21	0.21	0.21	0.21	0.21	-1%

Annex A Expansion of acronyms

Figure A.1 provides a single point of reference for all the acronyms referenced in this report.

Figure A.1: Expansion of acronyms [Source: Analysys Mason, 2025]

Acronym	Expansion	Acronym	Expansion
1G	First generation of mobile telephony	FOAS	Fixed originating access service
2G	Second generation of mobile telephony	FTAS	Fixed terminating access service
3G	Third generation of mobile telephony	GHz	Gigahertz
4G	Fourth generation of mobile telephony	gNodeB	Denotes the 5G equivalent of a base station
5G	Fifth generation of mobile telephony	HCIS	Hierarchical cell identification scheme
ABS	Australian Bureau of Statistics	HEO	Hypothetical efficient operator
ACCC	Australian Competition and Consumer Commission	HLR	Home location register
ACMA	Australian Communications and Media Authority	HSS	Home subscriber server
ACT	Australian Capital Territory	IMS	IP multimedia subsystem
AMR-WB	Adaptive multi-rate wideband	IM-SSF	IP multimedia service switching function
ASMG	Australian spectrum map grid	IP	Internet protocol
ATCF	Access transfer control function	LMA	Last-mile access
AUD	Australian dollar	LRAIC	Long-run average incremental cost
AWL	Area-wide apparatus licence	LRIC	Long-run incremental cost
BGCF	Border gateway control function	LTE	Long-term evolution
BHE	Busy-hour Erlangs	M2M	Machine to machine
CSCF	Call session control function	MEA	Modern equivalent asset
DNS	Domain name system	MGCF	Media gateway control function
ED	Economic depreciation	MGW	Media gateway
EME	Enhanced electromagnetic energy	MHz	Megahertz
eNodeB	4G equivalent of a base station	MME	Mobility management entity
EPMU	Equi-proportionate mark-up	MMS	Multimedia message service
ESL	Expiring spectrum licences	MMTel	Multimedia telephony service
FAC	Fully allocated cost	MNO	Mobile network operator
FBB	Fixed broadband	MOCN	Multi-operator core network
FDD	Frequency division duplex	MTAS	Mobile terminating access services
FNO	Fixed network operator	MVNO	Mobile virtual network operator

Acronym	Expansion	Acronym	Expansion
NPV	Net present value	SLT	Spectrum licence tax
NR	New radio	SMC	Small cell
PCC	Policy and charging control	SMS	Short message service
PCRF	Policy and charging rules function	SP	Service provider
PGW	Packet data network gateway	S-RAN	Single radio access network
Pol	Point of interconnect	SS7	Signalling system 7
PV	Present value	TAS	Tasmania
RAN	Radio access network	TDD	Time division duplex
RKR	Record keeping rules	TSLRIC	Total service LRIC
RU	Remote unit	VC	Victoria
SA	Statistical area/standard annuity	VoIP	Voice over internet protocol
SA	Southern Australia	VoLTE	Voice over LTE
SBC	Session border controller	VoNR	Voice over new radio
SCC-AS	Service centralisation and continuity application server	VoWiFi	Voice over Wi-Fi
SGW	Serving gateway	WACC	Weighted average cost of capital
SIO	Service in operation	Wi-Fi	Wireless fidelity (a wireless LAN standard)
SIP	Session initiation protocol		

Annex B Coverage calculations

In this section, we describe how the coverage inputs are derived in the model.

The ACCC gathers and reviews infrastructure concerning mobile infrastructure in Australia on an annual basis. In particular, it has assembled databases concerning the site locations and information for the three national MNOs, as well as coverage maps for each operator by technology and frequency. For the draft model, we have used the data collected for the year 2024.³⁰ The data collected for the year 2025 will be used for the final model.

The coverage map files are large datasets and it has proven difficult to assess the area coverage using these files. Therefore, we have adopted a point-based calculation, where Australia has been split into a highly detailed grid of squares.

The Australian government has developed a bespoke grid called the Australian spectrum map grid (ASMG). This is a hierarchical subdivision of the country, with the Level 4 ('L4') subdivision of the country illustrated in Figure B.1 below (these squares are 3 degrees of arc wide and tall, and are referred to as '3 degree cells').

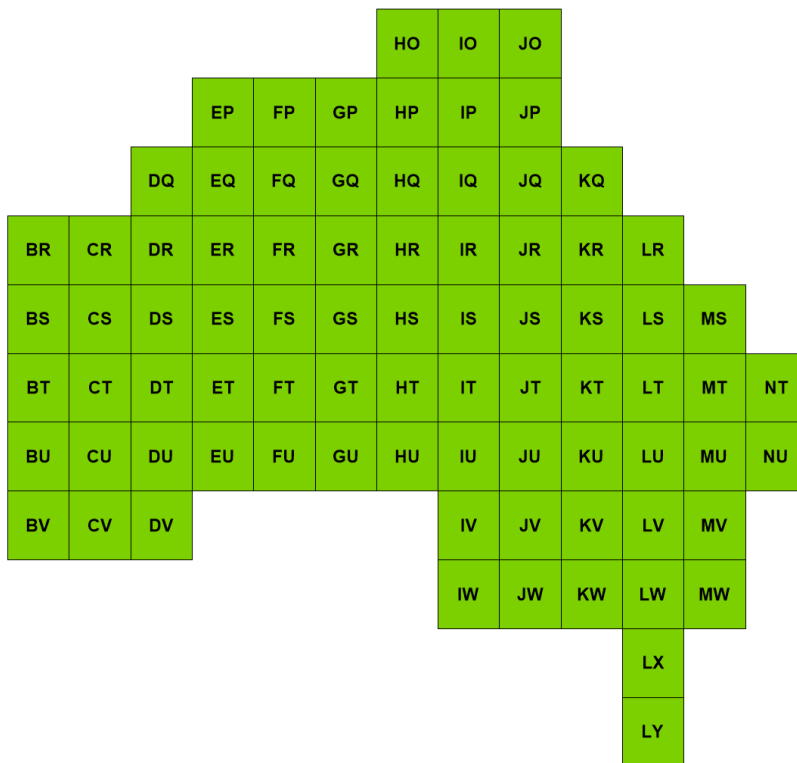

Figure B.1: Level 4 (L4) subdivision of Australia using the ASMG [Source: ACMA,³¹ 2025] [Source: Analysys Mason, 2025]

³⁰ This data is published at <https://data.gov.au/data/dataset/accc-mobile-infrastructure-report-data-release>.

³¹ Geographical data on the ASMG is available [here](#).

The grid squares above can be further subdivided. Using the square 'JS' as an example:

- the L4 square labelled JS divides into 9 L3 squares ('1-degree cells', labelled JS1–JS9)
- the L3 square labelled JS5 divides into 16 L2 squares ('15-minute cells', labelled JS5A–JS5P)
- the L2 square labelled JS5G divides into 9 L1 squares ('5-minute cells', labelled JS5G1–JS5G9)
- the L1 square labelled JS5G1 divides into 25 L0 squares ('1-minute cells', labelled JS5G1A–JS5G1Y).

Regional spectrum licences are defined to correspond to a part of Australia precisely defined by a set of Level 1/2/3/4 grid squares from this system.

In order to assess the coverage of the mobile operators, the Level 0 grid squares have been used, of which there are just over 3 million covering Australia. For each of these grid squares, it has been identified whether or not the square intersects remote/very remote areas of Australia, according to the ABS definition of remoteness areas:³²

- where the L0 grid square intersects remote/very remote areas of Australia, we identify a subgrid of 16 squares (4×4) and their centroids
- otherwise, we identify a subgrid of 256 squares and their centroids (16×16).

An illustration of these subgrids is provided below in Figure B.2.

Figure B.2: Illustration of subgrids [Source: Analysys Mason, 2025]

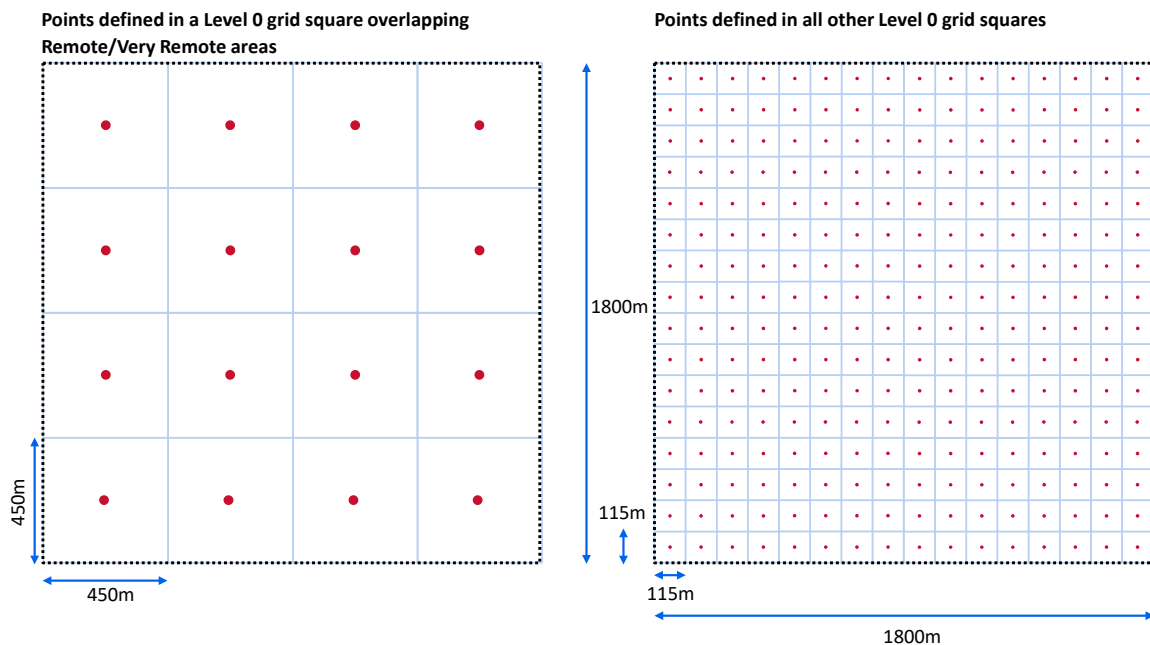

³² See the ABS website [here](#).

The SA2 area and SA1 area for each centroid is then derived. For each point, it is then determined whether it lies within any of the following coverage areas:

- Telstra network (any technology/frequency)
- TPG Telecom network (any technology/frequency)
- Optus network (any technology/frequency)
- Telstra 4G network (any frequency)
- TPG Telecom 4G network (any frequency)
- Optus 4G network (any frequency)
- Telstra 5G network (any frequency)
- TPG Telecom 5G network (any frequency)
- Optus 5G network (any frequency)
- The MOCN launched by Optus/TPG Telecom (using a coverage map submitted to the ACCC).

The total number of points considered within our methodology is shown below in Figure B.3.

Figure B.3: Total number of points considered [Source: Analysys Mason, 2025]

Geotype	Total number of points from grid squares overlapping Remote/Very Remote areas	Total number of points from other grid squares
Major Cities: Very high density	–	150 972
Major Cities: High density	–	422 389
Major Cities: Medium density	–	928 683
Major Cities: Low density	–	320 600
Inner Regional: Higher density	–	754 211
Inner Regional: Lower density	–	22 162 872
Outer Regional: Higher density	–	243 275
Outer Regional: Lower density	–	69 550 598
Remote: Higher density	2 604	–
Remote: Lower density	4 782 543	1 131 518
Very Remote: Higher density	202	–
Very Remote: Lower density	29 134 823	31 529
Islands	152 046	184 553
Total	34 072 218	95 881 200

For each point, the number of network operators deemed to be present at each location is then derived. We calculate an option to either include or exclude the MOCN coverage from this step, due to uncertainty in the coverage data.

For the case where the MOCN coverage is excluded, the actual coverage of the three operators is used as of 2024. For the case where the MOCN is included, we have made the assumption that any TPG Telecom coverage in 2024 within the MOCN coverage map is assumed to be deactivated. This assumption will not be required when the 2025 coverage maps are used, since the TPG Telecom coverage maps will explicitly show their remaining network.

These results are then aggregated by SA1 area so that the covered population can be calculated. This is estimated based on the points covered in the SA1 using the following equation:

$$\text{Coverage of SA1} = \frac{(16 \times \text{remote/very remote points covered}) + (\text{other points covered})}{(16 \times \text{remote/very remote points in area}) + (\text{other points in area})}$$

The results for the calculation, regardless of technology (including MOCN coverage), are shown below in Figure B.4.

Figure B.4: Population coverage outputs (including MOCN coverage) [Source: Analysys Mason, 2025]

Geotype	Proportion of population covered			Number of operators
	1 MNO	2 MNOs	3 MNOs	
Major Cities: Very high density	–%	0.0%	98.9%	2.97
Major Cities: High density	–%	0.0%	99.7%	2.99
Major Cities: Medium density	0.0%	0.5%	99.4%	2.99
Major Cities: Low density	0.1%	6.2%	93.7%	2.93
Inner Regional: Higher density	0.1%	44.0%	55.9%	2.56
Inner Regional: Lower density	3.2%	63.6%	32.2%	2.24
Outer Regional: Higher density	0.1%	52.2%	47.5%	2.47
Outer Regional: Lower density	8.6%	80.0%	8.0%	1.84
Remote: Higher density	0.0%	89.6%	–%	1.79
Remote: Lower density	21.3%	66.5%	0.0%	1.33
Very Remote: Higher density	–%	95.0%	–%	1.90
Very Remote: Lower density	41.0%	36.2%	–%	0.72
Islands	19.7%	12.0%	57.9%	1.98
Overall	1.14%	16.21%	81.73%	2.78

The results for the calculation regardless of technology (excluding MOCN coverage) are shown below in Figure B.5.

Figure B.5: Population coverage outputs (excluding MOCN coverage) [Source: Analysys Mason, 2025]

Geotype	Proportion of population covered			Number of operators
	1 MNO	2 MNOs	3 MNOs	
Major Cities: Very high density	–%	0.0%	98.9%	2.97
Major Cities: High density	–%	0.0%	99.7%	2.99
Major Cities: Medium density	0.0%	0.1%	99.8%	3.00
Major Cities: Low density	0.1%	0.6%	99.4%	2.99
Inner Regional: Higher density	0.0%	0.4%	99.6%	3.00
Inner Regional: Lower density	1.8%	8.1%	89.6%	2.87
Outer Regional: Higher density	0.0%	1.0%	98.8%	2.98
Outer Regional: Lower density	6.7%	24.8%	66.1%	2.55
Remote: Higher density	0.0%	6.0%	83.6%	2.63
Remote: Lower density	20.8%	42.6%	24.7%	1.80
Very Remote: Higher density	–%	95.0%	–%	1.90
Very Remote: Lower density	40.8%	28.8%	7.6%	1.21
Islands	19.6%	7.6%	62.5%	2.22
Overall	0.9%	2.5%	95.8%	2.93

We note that this consideration of the MOCN coverage is a temporary solution, based on the data available at the time of writing. We expect that the treatment of the MOCN coverage will be fully implemented for the final model when updating the inputs with the 2025 coverage maps, expected to be released by the ACCC later in the year.

Annex C Derivation of inputs for the model

In this section, we describe how we have used data from operators to derive key inputs in the model.

Figure C.1: Derivation of model inputs [Source: Analysys Mason, 2025]

Input	Worksheet	Derivation
Subscribers	<i>InMkt</i>	<ul style="list-style-type: none"> Total market subscribers are calculated from operator inputs for RKR reporting, shared by the ACCC
Proportion of 5G enabled handsets	<i>InMkt</i>	<ul style="list-style-type: none"> A weighted average forecast technology mix of handsets is calculated using inputs from operators and handset subscribers from RKR reporting
Traffic per subscriber	<i>InMkt</i>	<ul style="list-style-type: none"> Market average traffic per subscriber inputs are calculated from operator inputs for RKR reporting, shared by the ACCC Market average traffic per subscriber inputs pre-2019 are calculated from operator inputs to the MTAS 2020 modelling process
Proportion of outgoing fixed voice minutes to on-net	<i>InMkt</i>	<ul style="list-style-type: none"> Operator inputs are used to derive an estimated on-net proportion of outgoing fixed voice minutes
Mobile data technology migration profile	<i>InMkt</i>	<ul style="list-style-type: none"> Operator inputs inform the migration profile to 5G
Asset unit capex inputs	<i>InAsset</i>	<ul style="list-style-type: none"> Average unit capex is derived from operator inputs for network equipment and infrastructure
Asset unit opex inputs	<i>InAsset</i>	<ul style="list-style-type: none"> Average unit opex is derived from operator inputs for network equipment and infrastructure
Spectral efficiency	<i>InNwDes</i>	<ul style="list-style-type: none"> Average spectral efficiency inputs are calculated from operator inputs for different bands and different radio access technologies
Split of LMA links by technology	<i>InNwDes</i>	<ul style="list-style-type: none"> Market-level split is derived from operator inputs on LMA link type
Service demand by geotype	<i>NwLoad</i>	<ul style="list-style-type: none"> Operator inputs for traffic by site have been used to create splits for service demand by geotype
Busy-hour ratios	<i>NwLoad</i>	<ul style="list-style-type: none"> Calculated from operator inputs on typical network utilisation

Annex D Overview of the network design calculation flows

In this annex, we provide an overview of the network design calculation flow used in the model, which consists of two parts:

- Annex D.1 describes the network loading calculation
- Annex D.2 describes the network design calculation.

D.1 Network loading

The *NwLoad* worksheet calculates the loading at the various levels of the network based on the traffic throughput.

- 1. Market demand by network services*

 - Links in the total market demand by network services.
- 2. Split of service demand by geotype (national scale)*

 - Links in splits of service demand by geotype at a national scale, for each of voice, SMS/MMS, data and subscribers.
- 3. Assumed operator demand by network service and geotype (radio-level)*

 - Links in operator market share by geotype from the coverage analysis
 - Multiplies the total market demand by the operator's market share and split of service demand by geotype to obtain the operator demand by network service and geotype.
- 4. Assumed operator demand by network service (radio-level)*

 - Summarises the previous step to calculate total operator demand by network service.
- 5. Split of service demand by geotype (modelled operator)*

 - Using the outputs from steps 3 and 4, calculates the split of service demand by geotype for the modelled operator, for each of voice, SMS/MMS, data and subscribers.
- 6. Split of radio demand by geotype (modelled operator)*

 - Using the outputs from steps 3 and 4, and the number of radio legs per traffic unit for each network service, calculates the split of radio demand by geotype for the modelled operator, for each of voice, SMS/MMS, data, and subscribers.
- 7. Conversion factors*

 - Calculates factors for conversion of the following:
 - MB per voice minute, separately for LTE and 5G NR

- MB per SMS, separately for LTE and 5G NR
 - Minutes per SMS, separately for LTE and 5G NR.
8. *Loading calculation in the voice busy-hour (radio)*
- Specifies inputs for
 - busy days in a year for mobile voice and fixed voice (261)
 - proportion of total traffic that occurs in the busy days for mobile voice (80%) and fixed voice (89%)
 - proportion of busy-day traffic that occurs in the mobile voice busy hour for mobile voice (9.0%), and the fixed voice busy hour for fixed voice (11.0%)
 - Calculates busy-hour Erlangs (BHEs) for each voice service, starting from the annual traffic volumes at radio level calculated in step 4
 - Calculates busy-hour Mbit/s for each voice service in the voice busy hour.
9. *Loading calculation in the data busy-hour (radio)*
- Specifies inputs for
 - busy days in a year for mobile data (365)
 - proportion of total traffic that occurs in the busy days for data (100% by definition)
 - proportion of busy-day traffic that occurs in the data busy-hour for voice (4.0%), SMS (4.0%) and data: 4G (6.0%) and 5G (6.0%)
 - Calculates busy-hour traffic for voice, SMS and data in the data busy hour, starting from the annual traffic volumes at radio level calculated in step 4.
10. *Network loading for dimensioning - LTE radio*
- Using the outputs from step 9, and the number of radio legs per traffic unit for each network service, calculates busy-hour radio traffic for voice, SMS and data services on LTE radio in the data busy hour
 - Using the outputs from step 6, distributes busy-hour LTE radio traffic by geotype, for each of voice, SMS and data
 - Calculates total LTE traffic Mbit/s in data busy hour using conversion factors.
11. *Network loading for dimensioning - 5G NR radio*
- Repeats step 10 for 5G NR radio, to calculate 5G NR traffic Mbit/s in data busy hour.
12. *Assumed operator demand by network service (core level)*
- Links in operator's core network market share by network service: 33.3% for mobile services and 20% for fixed services
 - Multiplies the total market demand by the operator's core network market share by network service to obtain the operator demand by network service (core-level).
13. *Loading calculation in the*
- Calculates BHEs for each voice service, starting from the annual traffic volumes at core-level calculated in step 12
 - Calculates busy-hour Mbit/s for each voice service in the voice busy hour.

*voice busy hour
(core)*

*14. Loading
calculation in the
data busy-hour
(core)*

- Calculates busy-hour traffic for voice, SMS and data in the data busy hour, starting from the annual traffic volumes at core level calculated in step 12.

*15. Network
loading for core
network equipment*

- Specifies inputs for:
 - call attempts per successful call (1.20)
 - average call duration of two minutes
- Links in BHEs in the voice busy hour for mobile voice and fixed voice from step 13
- Calculates mobile core network measures for mobile core assets
- Calculates fixed core network measures for fixed core assets.

D.2 Network design

In this section, we provide an overview of the following worksheets:

- the *InNwDes* worksheet specifies a wide range of inputs used in the design of the network (Annex D.2.1)
- the *NwDes* worksheet calculates the asset requirements over time for the modelled operator's network (Annex D.2.2).

D.2.1 *InNwDes* worksheet

1. Spectrum inputs

- Amount of spectrum in each coverage and capacity layer, linked from the assumed operator holdings
- Size of a radio channel, in MHz
- Calculation of the number of channels available.

2. Coverage inputs

- Coverage analysis used to calculate operator market share by geotype
- Calculation of area coverage in each geotype by technology
- Cell radius and cell area for outdoor coverage
- Cell 'pi' of 2.6 to calculate the cell area covered
- Frequency used for coverage added in each year, linked from the selected operator
- Coverage area by technology and geotype.

3. LTE inputs

- Input of LTE capacity parameters
- Input of LTE spectral efficiency by band
- Input of throughput of an LTE voice channel (adaptive multi-rate wideband (AMR-WB) standard codec)

- Input of LTE carrier parameters, including the cell peak to effective rate for data throughput of 40%
- Specification of the LTE carrier upgrades ladder
- Calculation of LTE spectral efficiency by spectrum band
- Calculation of spectrum volume per LTE carrier by geotype and spectrum band
- Calculation of throughput per LTE carrier by geotype and spectrum band
- Calculation of number of LTE carriers available per sector by geotype and spectrum band
- Calculation of order of deployment for LTE carriers by spectrum bands - indexed - adjusted for multiple carriers in the same band
- Calculation of order of deployment for LTE carriers by geotype
- Calculation of throughput for LTE carriers - by order of deployment
- Calculation of cumulative throughput for LTE carriers - by order of deployment.

4. 5G NR inputs

- Input of 5G NR capacity parameters
- Input of 5G NR spectral efficiency by band
- Input of throughput of an 5G NR voice channel (AMR-WB standard codec)
- Input of 5G NR carrier parameters, including the cell peak to effective rate for data throughput of 40% and $\times 2$ multiplier for massive MIMO
- Specification of the 5G NR carrier upgrades ladder
- Calculation of 5G NR spectral efficiency by spectrum band
- Calculation of spectrum volume per 5G NR carrier by geotype and spectrum band
- Calculation of throughput per 5G NR carrier by geotype and spectrum band
- Calculation of number of 5G NR carriers available per sector by geotype and spectrum band
- Calculation of order of deployment for 5G NR carriers by spectrum bands - indexed - adjusted for multiple carriers in the same band
- Calculation of order of deployment for 5G NR carriers by geotype
- Calculation of throughput for 5G NR carriers - by order of deployment
- Calculation of cumulative throughput for 5G NR carriers - by order of deployment.

5. Single-RAN inputs

- Input of frequencies suitable for S-RAN units
- Calculation of frequencies assigned by geotype and technology
- Calculation of S-RAN configurations suitable for single and multiple technology sites by geotype.

6. Physical sites

- Input of percentage for sites deployed as single technology or co-located sites (90% for LTE physical sites and 98% for 5G NR physical sites)

- Input for split of sites by type.
- 7. *Last-mile access inputs*
 - Specification of the LMA link rate ladders
 - Input for split of links by backhaul technology
 - Inputs for aggregation transmission.
- 8. *Core network inputs*
 - Input of core network node locations and core network transmission links.
- 9. *Mobile core network assets*
 - Input of mobile core network design inputs.
- 10. *Fixed core network assets*
 - Input of fixed core network design inputs.

D.2.2 *NwDes* worksheet

The *NwDes* worksheet calculates the asset requirements over time for the modelled operator's network.

1. *LTE Sites*
 - Links in the area covered by LTE by geotype
 - Links in area per site for coverage
 - Calculates the total number of sites for coverage
 - Links in LTE BH Mbit/s to be carried on the network
 - Calculates LTE BH Mbit/s per coverage cell, including peak-achieved factor and carrier utilisation
 - Calculates LTE capacity: maximum bitrate usable per site, Mbit/s
 - Calculates number of carriers per site required to support the maximum bitrate usable
 - Calculates minimum number of LTE carriers at coverage sites
 - Calculates the number of LTE carriers on coverage sites
 - Calculates the number of capacity sites
 - Calculates the number of LTE carriers on capacity sites
 - Calculates the total number of LTE carriers
 - Calculates the total number of LTE sites.
2. *5G NR sites*
 - Repeats step 1 for 5G NR.
3. *Single RAN*
 - Links in the S-RAN configurations suitable for single and multiple technology sites by geotype
 - Links in number of single and multiple technology sites by geotype from step 4
 - Calculates the number of S-RAN units for each S-RAN configuration by geotype

- Calculates the number of S-RAN units for each S-RAN configuration by remoteness area type.
4. *Physical sites*
- Links in the total number of LTE sites (from step 1) and total number of 5G NR sites (from step 2)
 - Links in the proportion of physical sites available for colocation by technology, in each geotype
 - Calculates the number of single and multiple technology sites by geotype and remoteness area type
 - Links in proportion of sites by site type, and calculates splits into site type (tower, rooftop, small cell, indoor) for each remoteness area type.
5. *Last-mile access*
- Links in the total BH traffic by technology
 - Calculates BH traffic per site by technology
 - Calculates traffic on multi-technology and single technology sites
 - Links in LMA link rates
 - Calculates LMA link capacity requirements on multi-technology and single technology sites
 - Determines transmission method (fibre, owned microwave, satellite) based on geotype and required speed, following to a predefined ladder of options
 - Calculates the number of LMA links by transmission type according to that same rate ladder, for each remoteness area type.
6. *Aggregation layer*
- Calculates the number of aggregation hubs required using inputs for proportion of sites co-located and number of sites per hub
 - Calculates the number of aggregation backhaul fibre links using inputs for proportion of hubs served by fibre
 - Calculates the number of aggregation backhaul microwave links using inputs for proportion of hubs served by microwave and number of microwave hops per aggregation link.
7. *Mobile core network*
- Links in network design inputs for mobile core network
 - Links in mobile core network measures from *NwLoad* worksheet
 - Calculates network design of mobile core network.
8. *Fixed core network*
- Links in network design inputs for fixed core network
 - Links in fixed core network measures from *NwLoad* worksheet
 - Calculates network design of fixed core network.

Annex E Overview of the costing calculation flows

In this annex, we provide an overview of the costing calculation flows used in the model, consisting of two parts:

- Annex E.1 describes the costing calculation for network expenditure and annualisation
- Annex E.2 describes the costing calculation for services.

E.1 Network expenditure and annualisation

In this section, we provide an overview of the network expenditure and annualisation calculations used in the model:

- defining the list of assets on the *InAsset* worksheet (Annex E.1.1)
- specifying the allocations and payments for spectrum on the *InSpectrum* (Annex E.1.2)
- determining the assets purchased in each year on the *NwDeploy* worksheet (Annex E.1.3)
- calculating unit cost trends for each asset over time on the *InCostTrends* worksheet (Annex E.1.4)
- calculating the total annual investment and total annual operating costs *NwTotalCost* (Annex E.1.5).

E.1.1 *InAsset* worksheet

- | | |
|---------------------------------------|---|
| <p>1. <i>Standard cost inputs</i></p> | <ul style="list-style-type: none"> • For a given set of cost input categories, specifies an assumed lifetime, planning period, proportion of asset replaced per annum and opex as a proportion of capex for each category. |
| <p>2. <i>Inputs by asset</i></p> | <ul style="list-style-type: none"> • For each asset, specifies: <ul style="list-style-type: none"> – asset name – cost category – cost input category (from the list in the table of standard cost inputs) – retirement period³³ – lifetime, planning period and opex as a proportion of capex based on the cost input category – unit capex in real 2025 AUD – unit opex in real 2025 AUD (fixed, and as a proportion of capex). |

³³ By setting the value to 0, 1 or 2, the new MTR model will remove the assets as traffic reduces, either in the same year, one year later, or two years later respectively. By setting the value to 100, the new MTR model will retain the asset in the network until the last year of operation.

E.1.2 *InSpectrum* worksheet

The *InSpectrum* worksheet specifies the allocations and payments for spectrum, and includes a specific economic depreciation calculation for spectrum payments.

1. *Spectrum fees calculation*
 - Calculates the spectrum fees incurred by band for each modelled year
 - Up-front fees are calculated as capex
 - Annual spectrum usage fees are calculated as opex.

2. *Conversion factors*
 - Specifies conversion of SMS to minutes
 - Specifies conversion of data megabytes to minutes
 - Defines other inputs to calculate radio equivalent minutes by service, including
 - radio loading factors by traffic type
 - ringing time per minute
 - soft-handover erlangs traffic
 - softer-handover traffic.

3. *Inputs by service for the modelled operator*
 - Links in market-level demand by network service and demand by traffic type
 - Links in operator-level demand by network service, and aggregates demand by traffic type
 - Calculates operator market share of demand by traffic type
 - Links in split of traffic by technology for spectrum service lists (this includes 2G and 3G services, as well as 4G and 5G services)
 - Calculates operator market share of traffic by technology for spectrum services
 - Calculates total operator traffic for spectrum services.

4. *General inputs*
 - Calculates operator traffic volumes to voice-equivalent minutes by technology
 - Links in following inputs
 - calendar year inflation
 - inflation multiplier
 - real-terms WACC
 - real discount rate divider.

5. *Economic depreciation calculation*
 - Defines cost trend inputs by band, separately for capex and opex
 - Links in spectrum opex and capex payments by band in real terms
 - Calculates discounted capex and opex, and total present value
 - Calculates asset output by spectrum band using mapping of spectrum band to technology
 - Calculates total output indexed on cost trend, separately for capex and opex

- Calculates cost per unit output, separately for capex and opex
- Calculates economic capex and opex by band
- Calculates total economic cost by technology
- Calculates total operator terminated minutes by technology
- Calculates the spectrum cost per terminated minute by technology.

E.1.3 *NwDeploy* worksheet

The network design algorithms compute the network elements that are required to support a given demand in each year. In order for these elements to be operational when needed, they need to be purchased in advance, in order to allow provisioning, installation, configuration and testing before they are activated. This is modelled for each asset by inputting a planning period between 0 (no planning required) and 18 months. The number of assets purchased in each year is derived on this worksheet, accounting for:

- additional assets required to provide incremental capacity
- equipment that has reached the end of its lifetime and needs to be replaced
- advanced purchase in both cases based on the assumed planning period.

The steps taken are described below.

- | | |
|---|--|
| <i>1. Network elements by year</i> | • Pulls together the assets required in the modelled network for each year in the modelling period. |
| <i>2. Network elements, accounting for network activation</i> | • Calculates network elements, accounting for network activation. |
| <i>3. Required units in full network</i> | • Produces required network elements by year, formatted appropriately for input into the retirement algorithm. |
| <i>4. Deployed assets with retirement algorithm</i> | • Determines the maximum number of units required of each asset and the first year in which this maximum is reached. |
| <i>5. Annual activation (including replacement)</i> | • Calculates the difference between the number of units required and the number of units previously deployed that are still active (this does not remove assets before the end of their lifetime even if they are no longer required). |

5. *Direct equipment purchases (incl. replacement)*
- Determines the equipment required across all replacement cycles, purchased prior to activation based on the planning period (fractional units of purchase are permissible on the basis that they reflect phasing of purchase over each modelled year).

E.1.4 *InCostTrends* worksheet

The cost of purchase for network assets varies over time. In the economic costing approach, the modern equivalent asset (MEA) provides the appropriate cost basis for purchase. Real-term unit asset cost trends are applied to 2025 unit asset costs to reflect the evolution of the modern technology unit asset costs over past and future time. The evolution of MEA unit asset costs also provides an important input into the economic depreciation calculation, as described in Annex E.2. Certain quantities for the economic depreciation calculation, including the capex/opex indices, are also calculated on the *InCostTrends* worksheet.

These calculations are described below.

1. *Equipment capex trends*
 - Specifies the year-on-year change in capex trends over time for a set of specified categories
 - Determines the year-on-year change in capex trends for each asset, based on a specified category
 - Calculates the cumulative year-on-year change in capex trends for each asset, indexed with the first modelled year set to be 1
 - Multiplies this capex index by the network element output, which is described in Annex E.2.2, to give the capex cost-weighted output.
2. *Equipment opex trends*
 - Specifies the year-on-year change in opex trends over time for a set of specified categories
 - Determines the year-on-year change in opex trends for each asset, based on a specified category
 - Calculates the cumulative year-on-year change in opex trends for each asset, indexed with the first modelled year set to be 1
 - Multiplies this opex index by the network element output, which is described in Annex E.2.2, to give the opex cost-weighted output.
3. *Unit capex per network element*
 - Calculates the unit capex by asset in each modelled year, using the MEA capex index, scaled by the capex index value in 2025. This ensures that the unit capex is determined relative to the base year of the inputs, which is 2025.
4. *Shut-down capex profile*
 - Determines a binary multiplier, which is zero after the network is assumed to be shut down and one otherwise.

- 5. *Unit opex per network element*
 - Calculates the unit opex by asset in each modelled year, using the MEA opex index, scaled by the opex index value in 2025. This ensures that the unit opex is determined relative to the base year of the inputs, which is 2025.
- 6. *Shut-down opex profile*
 - Determines a binary multiplier, which is zero when an asset has been assumed to be completely removed due to network shutdown; otherwise, the binary multiplier is one.

E.1.5 *NwTotalCost* worksheet

- 1. *Total annual capex*
 - Multiplies the unit capex derived in the *InCostTrends* worksheet by the number of assets purchased in each year, calculated in the *NwDeploy* worksheet
 - The capex is set to be zero for those assets in those year when the shut-down profile for capex from the *InCostTrends* worksheet is zero.
- 2. *Category totals*
 - Aggregates the total capex by asset derived above by cost category
 - Calculates total discounted capex.
- 3. *Cumulative capex*
 - Cumulates the capex by cost category over time, starting in the first year of the modelling period.
- 4. *Working capital allowance*
 - Calculates the working capital allowance in each year (currently assumed to be 30/365 – i.e. one calendar month – of the weighted average cost of capital (WACC))
- 5. *Total annual opex*
 - Multiplies the unit opex derived in the *InCostTrends* worksheet by the number of assets active in the network in each year, calculated in the *NwDeploy* worksheet
 - The opex is set to be zero for those assets in those year when the shut-down profile for opex from the *InCostTrends* worksheet is zero
 - The opex is also uplifted by the working capital allowance.
- 6. *Category totals*
 - Aggregates the total opex by asset derived above by cost category
 - Calculates total discounted opex
 - Calculates total and cumulative discounted expenditure (opex + capex).
- 7. *Opex recovery over time*
 - Calculates opex recover over time by multiplying operator network output (from *NwEleOut* worksheet) by opex cost per unit output (from ED worksheet)

- 8. *Full table of common number assets*
 - Determines full table of common number of assets.
- 9. *Full table of common cost proportions*
 - Calculates full table of common cost proportions.

E.2 Service costing

This section describes the implementation of the network service costing and economic depreciation algorithm used in the model. We describe this in several stages:

- Annex E.2.1 describes the routing factors inputs
- Annex E.2.2 describes the network element output calculations
- Annex E.2.3 describes the assumptions for the discount rates
- Annex E.2.4 describes the calculation steps implemented to derive economic costs
- Annex E.2.5 describes how the LRAIC (and LRAIC+) are derived in the model.

E.2.1 *InRF* worksheet

Routing factors determine the amount of each element's output required to provide each service. The routing factors used in the model are average traffic routing factors and are converted into equivalent traffic measures using a number of derived conversion factors.

- 1. *Source calculations*
 - Links in a series of standard technical parameters
 - Calculates factors for conversion of the following quantities on the air interface into minute equivalents:
 - SMS, separately for LTE and 5G NR
 - data megabytes, separately for LTE and 5G NR
 - Calculates factors for conversion of data traffic on transmission links.
- 2. *Routing factor options*
 - For a list of asset measure options, derives a routing factor for that option for each of the modelled services.
- 3. *Full routing factor table*
 - For each asset and each modelled service, identifies the routing factor from the above table based on the asset measure option for that asset.

E.2.2 *NwEleOut* worksheet

The quantity of network element output, by asset over time, is used as the basis on which to derive economic costs. This quantity is taken to be the annual sum of service demand produced by the asset,

weighted according to the routing factors of that asset for the modelled services. Network element output is calculated on the *NwEleOut* worksheet.

- | | |
|---|--|
| <i>1. Service demand for the network modelled</i> | • Links in the service volumes for the modelled network over time from the <i>NwLoad</i> worksheet. |
| <i>2. Service routing factors</i> | • Links in the full routing factor table from the <i>InRF</i> worksheet. |
| <i>3. Recovery profile</i> | • Currently set to be 0% before cost recovery is assumed to start and after cost recovery has ended, 100% otherwise. |
| <i>4. Recovery profile in binary form</i> | • Currently set to be 1 if the corresponding entry in the recovery profile above is nonzero, and zero otherwise. |
| <i>5. Network element output</i> | • Calculated as: |

$$\text{Service volumes} \times \text{routing factors} \times \text{binary profile}$$

E.2.3 *InDF* worksheet

The model operates in real terms and hence requires a real discount rate with which the modelled cashflows can be discounted when deriving present values. This is derived using the real cost of capital, specified on the *Control* worksheet.

- | | |
|---|--|
| <i>1. Real discount rate</i> | <ul style="list-style-type: none"> • Stores the nominal discount rate (WACC) • Derives the real discount rate • Derives the real discount rate multiplier • Derives the real discount rate divider |
| <i>2. Inflation data for conversion from real to nominal currency</i> | <ul style="list-style-type: none"> • Stores historic and forecast inflation • Derives the inflation multiplier from the consumer price index. |

E.2.4 *ED* worksheet

This worksheet is where the economic costs of capex/opex are calculated over time, using the above inputs and the unit asset cost trends from the *InCostTrend* worksheet, described in Annex E.1.4.

- | | |
|---------------------------------|--|
| <i>1. Capex per unit output</i> | <ul style="list-style-type: none"> • Calculated separately for each asset across the modelling period • Derived as the capex index over time scaled by a constant factor |
|---------------------------------|--|

- This factor is the ratio of the cumulative discounted asset capex and the cumulative discounted capex weighted output (referred to as ' $PV(\text{expenditure}) / PV(\text{output} \times \text{MEA price index})$ ' above).
2. *Opex per unit output*
- Calculated separately for each asset across the modelling period
 - Derived as the opex index over time scaled by a constant factor
 - This factor is the ratio of the cumulative discounted asset opex and the cumulative discounted opex weighted output (referred to as ' $PV(\text{expenditure}) / PV(\text{output} \times \text{MEA price index})$ ' above)
 - This is calculated separately to the capex per unit output since the asset unit capex trend could differ to the asset unit opex trend.
3. *Total cost per unit output*
- Calculates the sum of the capex per unit output and the opex per unit output, multiplied by the binary recovery profile.
4. *FAC per service unit*
- Calculates the multiplication of the cost per unit output matrix and the routeing factor matrix to give unit fully allocated costs (FAC) by service.
5. *Total economic costs*
- Calculates the total cost per unit output multiplied by the network element output
 - Calculates the total economic costs over time
 - Calculates the total discounted economic costs over time
 - Calculates the cumulative discounted economic costs over time
 - Calculates the present value of the economic costs.
6. *Total costs recovered by FAC*
- Multiplies the FAC per service unit by the modelled network service volumes
 - Calculates the total discounted FAC.

E.2.5 LRAIC+ worksheet

On this worksheet, economic costs are mapped to services and mark-ups are applied.

1. *Total economic costs*
- Links in the total economic costs by asset over time from the *ED* worksheet.
2. *Total common costs*
- Calculates common costs using the proportions from the *NwTotalCost* worksheet.
3. *Total incremental costs*
- Derives the difference between the total economic costs and common economic costs.
4. *Calculation of mark-ups*
- Calculates common network costs as a proportion of incremental economic costs in order to arrive at the EPMU.

- 5. Calculation of unit LRAIC*
- Calculates the incremental cost per unit output by multiplying the total cost per unit output from the *ED* worksheet by the common cost proportions
 - Calculates the incremental opex per unit output by multiplying the total opex per unit output from the *ED* worksheet by the common cost proportions
 - Multiplies the incremental cost per unit output matrix and the routing factor matrix to arrive at the unit LRAIC by service, and calculates the portion of which is opex
 - Multiplies the unit LRAIC by service by the network service volumes to derive the total LRAIC by service
 - For a selected year, calculates the breakdown of network service unit costs by asset and service, by multiplying the incremental cost per unit output in that year by the routing factors
 - Aggregates this breakdown by cost category
 - Calculates the total network service costs by asset and service for the selected year, and aggregates this breakdown by network category.
- 6. Calculation of unit LRAIC+*
- Applies the derived EPMU to the unit LRAIC by service to derive the unit LRAIC+ (network common costs) by service
 - Further applies separate mark-ups for the capex and opex components of the economic costs to reflect non-network common costs (LRAIC++)
- 7. Calculations of cost recovery*
- Multiplies the unit LRAIC+ by service by the network service volumes to derive the total LRAIC+ by service
 - Calculates the discounted LRAIC+ by service and the total present value of the LRAIC+
 - Calculates LRAIC++ recovered by network service.